



"A LONG DAY'S JOURNEY INTO NIGHT"

Directed by Bill Hayes

PALM BEACH DRAMAWORKS

ROUGH B/W ELEVATION as of 10.9.15

SCALE: 1/4" = 1'-0"



"A LONG DAY'S JOURNEY INTO NIGHT"

Directed by Bill Hayes

PALM BEACH DRAMAWORKS

ROUGH COLOR ELEVATION #1- as of 11.30.15

SCALE: 1/4" = 1'-0"

DESIGNED BY K.A. SOROKO



"A LONG DAY'S JOURNEY INTO NIGHT"

Directed by Bill Hayes

PALM BEACH DRAMAWORKS

ROUGH COLOR ELEVATION #2- as of 11.30.15

SCALE: 1/4" = 1'-0"

DESIGNED BY K.A. SOROKO

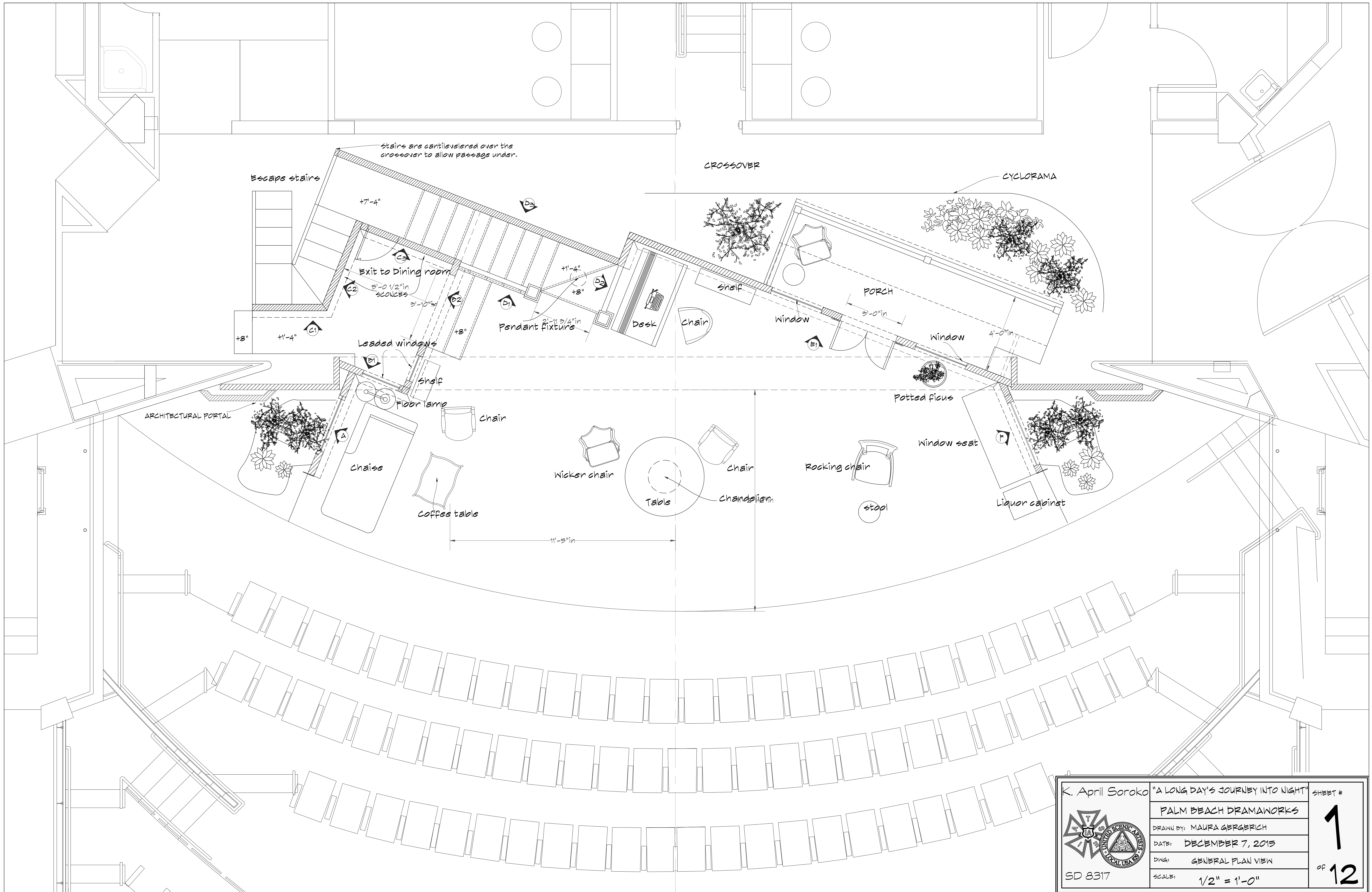

	K. April Soroko	"A LONG DAY'S JOURNEY INTO NIGHT"	SHEET #
	PALM BEACH DRAMAWORKS		1
	DRAWN BY: MAURA GERGERICH		OF
	DATE: DECEMBER 7, 2015		12
	DRAWING: GENERAL PLAN VIEW		
SD 8317	SCALE:	1/2" = 1'-0"	

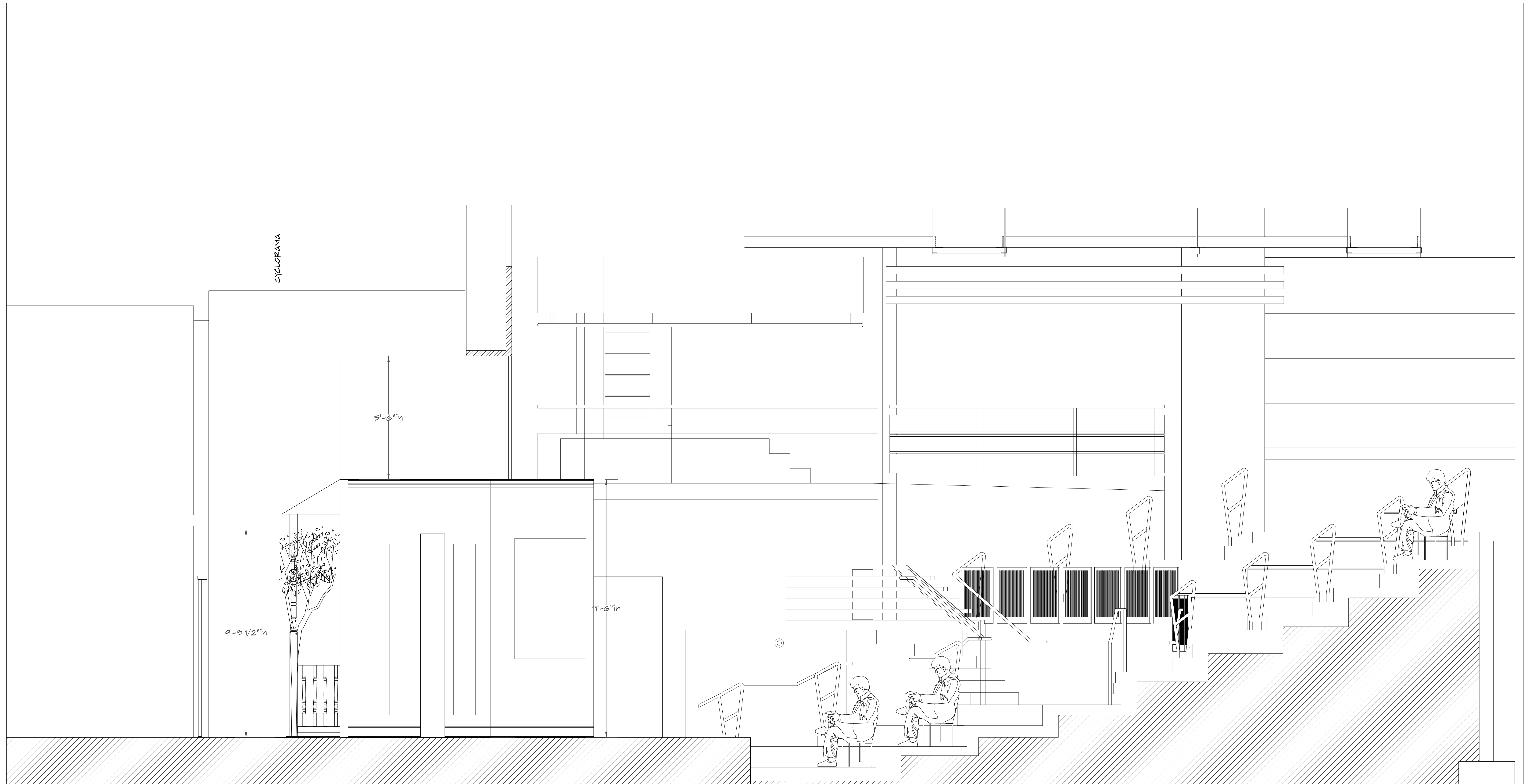

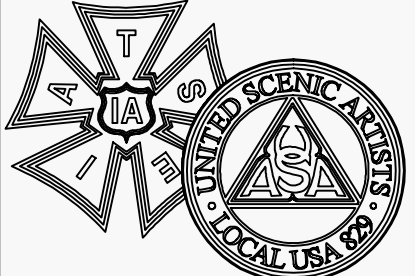
 SD 8317	K. April Soroko	"A LONG DAY'S JOURNEY INTO NIGHT"	SHEET #
	PALM BEACH DRAMAWORKS		2 OF 12
	DRAWN BY: APRIL SOROKO		
	DATE: DECEMBER 7, 2015		
	DWG: SL SECTION AT CENTER		
SCALE: 1/2" = 1'-0"			

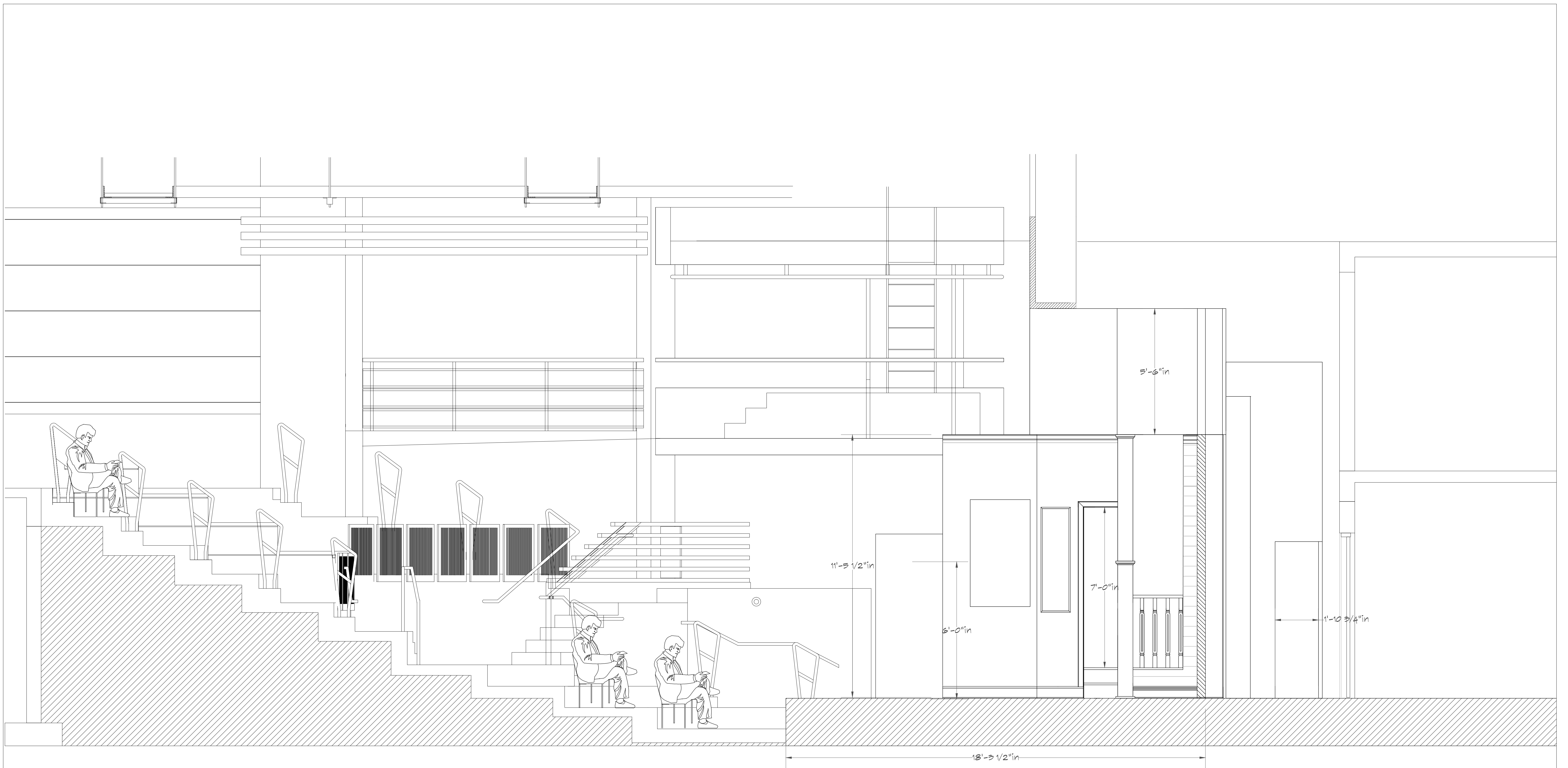

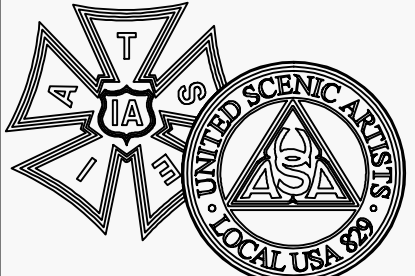
 SD 8317	K. April Soroko "A LONG DAY'S JOURNEY INTO NIGHT" SHEET #	3 OF 12
	PALM BEACH DRAMAWORKS	
	DRAWN BY: APRIL SOROKO	
	DATE: DECEMBER 7, 2015	
	DWG: SR SECTION AT CENTER	
SCALE: 1/2" = 1'-0"		

REVEAL WALL ELEVATION

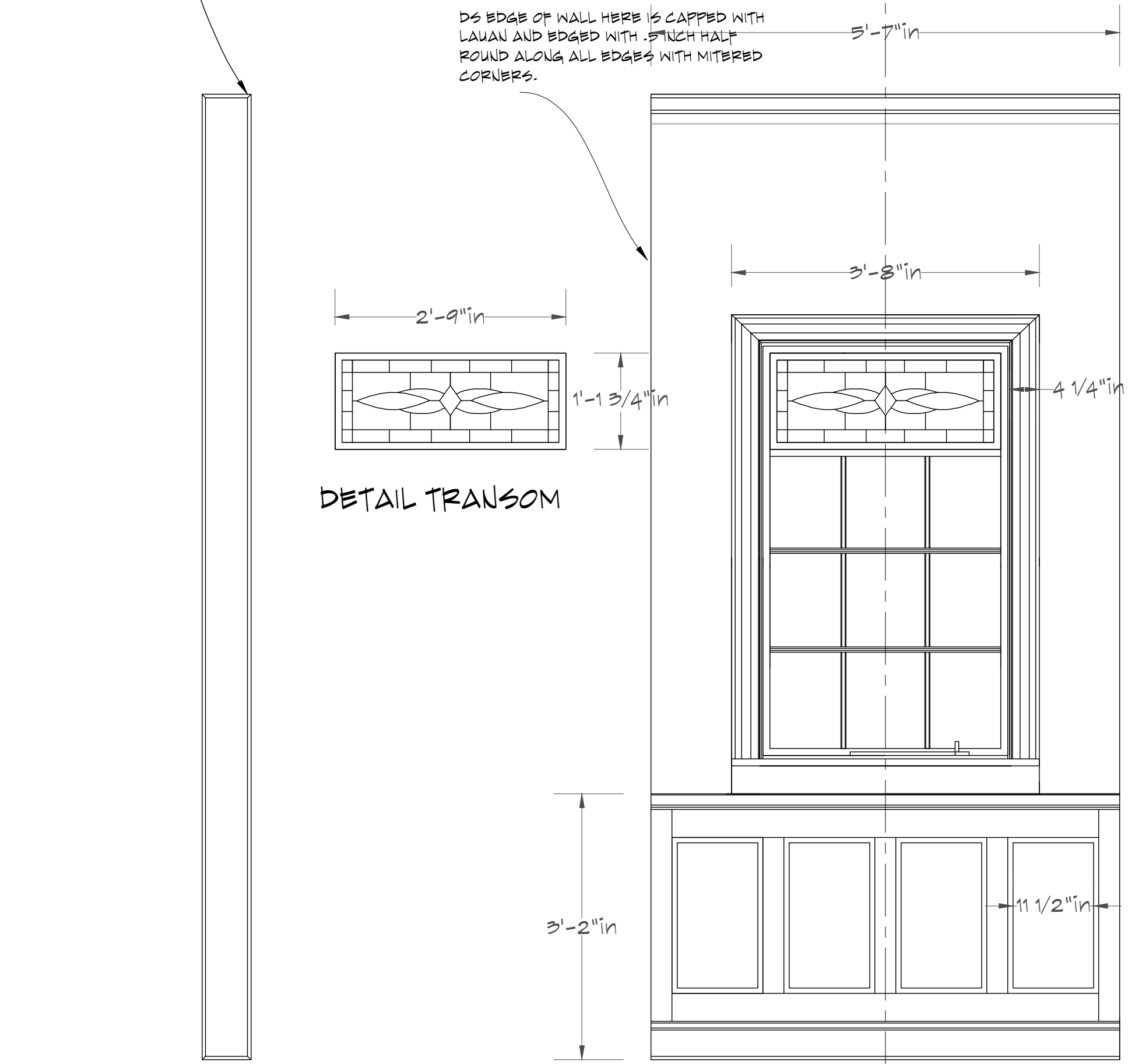

DETAIL TRANSOM

Upper portion of wall is covered with black divalgn.

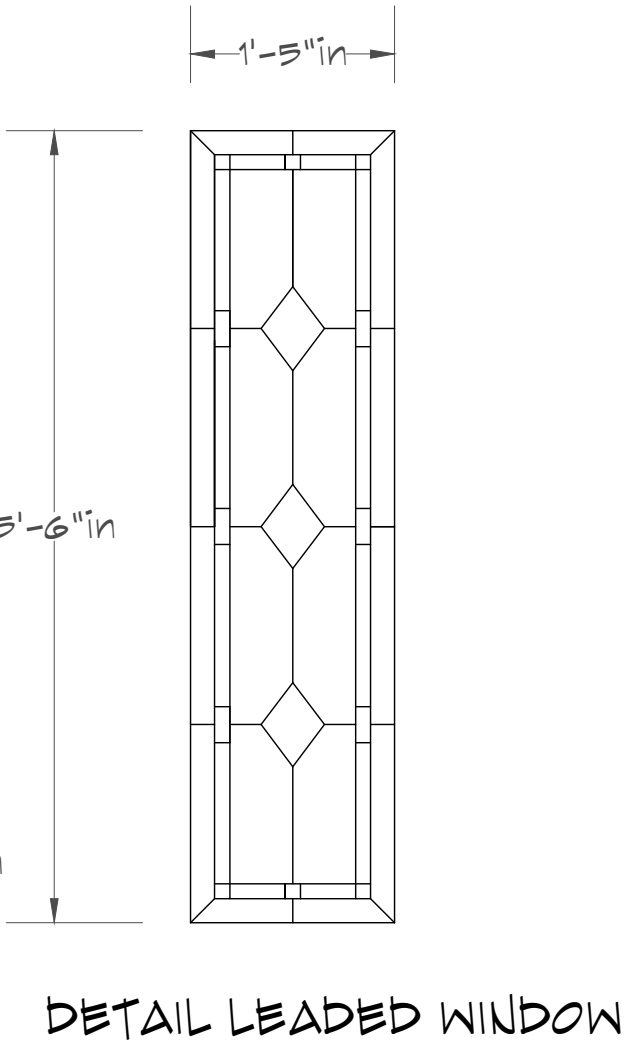

DETAIL LEADED WINDOW

DS EDGE OF WALL A ELEVATION VIEW

A ELEVATION VIEW

A SECTION VIEW

B1 ELEVATION VIEW

B1 SECTION VIEW

B2 ELEVATION VIEW

B2 SECTION VIEW

DS EDGE OF WALL A PLAN VIEW

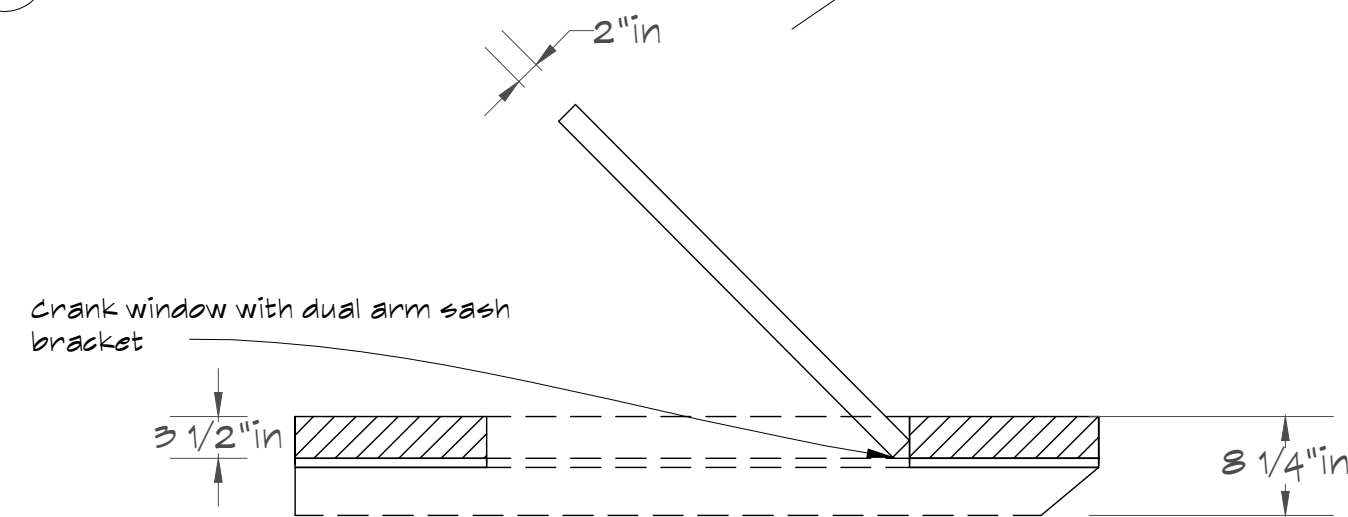

A PLAN VIEW

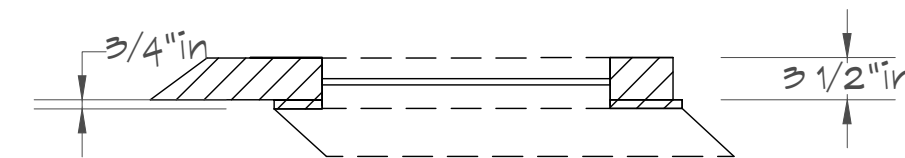

B1 PLAN VIEW

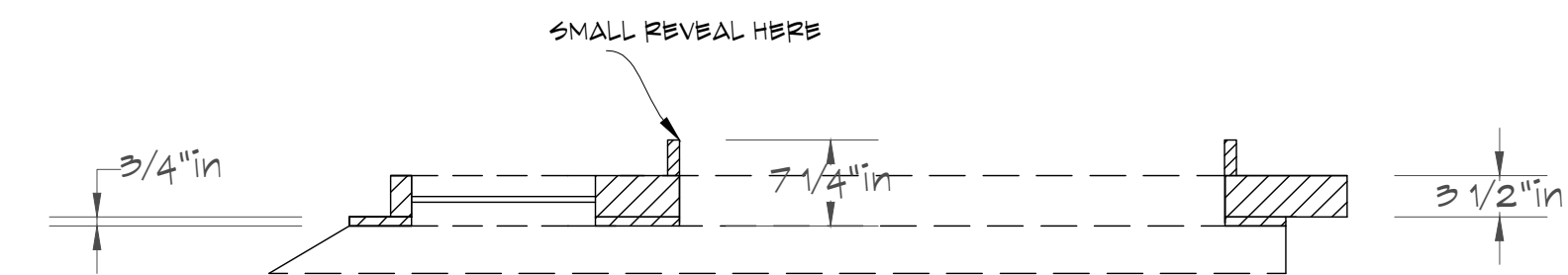

B2 PLAN VIEW

	K. April Soroko	"A LONG DAY'S JOURNEY INTO NIGHT"	SHEET #
	PALM BEACH DRAMAWORKS		4 OF 12
	DRAWN BY: MAURA GERGERICH		
	DATE: DECEMBER 7, 2015		
	DWG: DETAILS - WALLS A-B		
SD 8317	SCALE: 3/4" = 1'-0"		

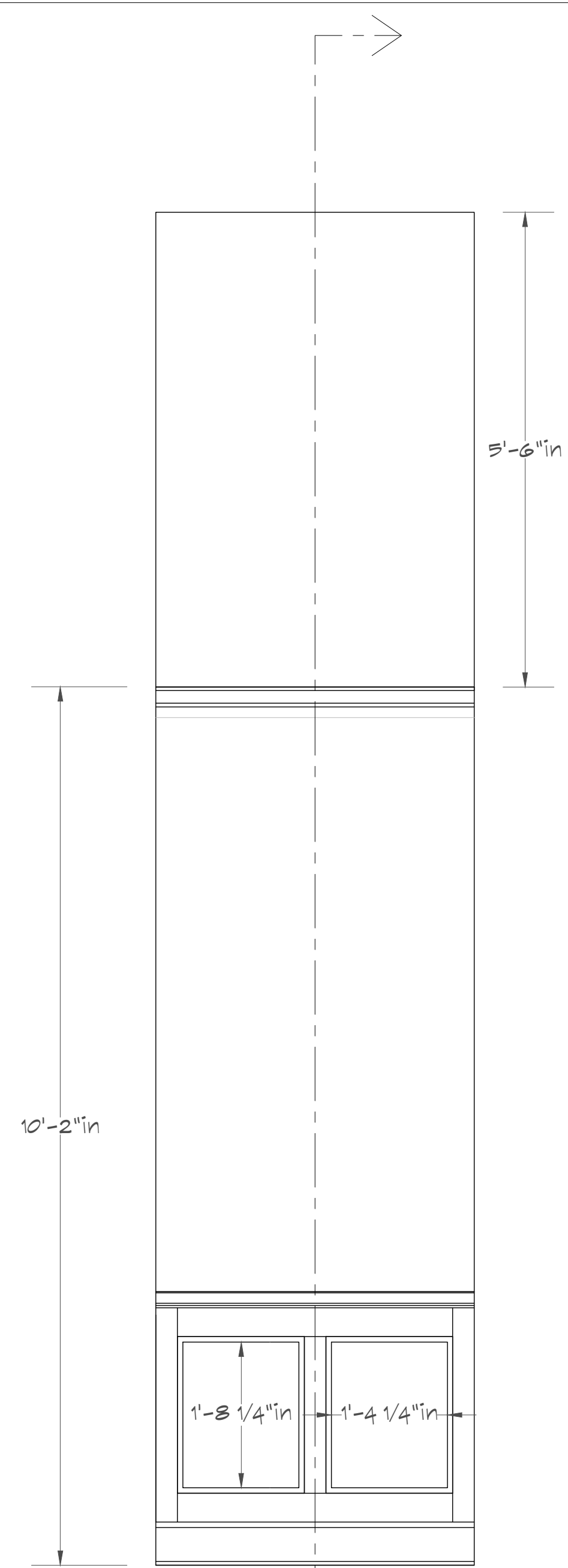

C1 ELEVATION VIEW

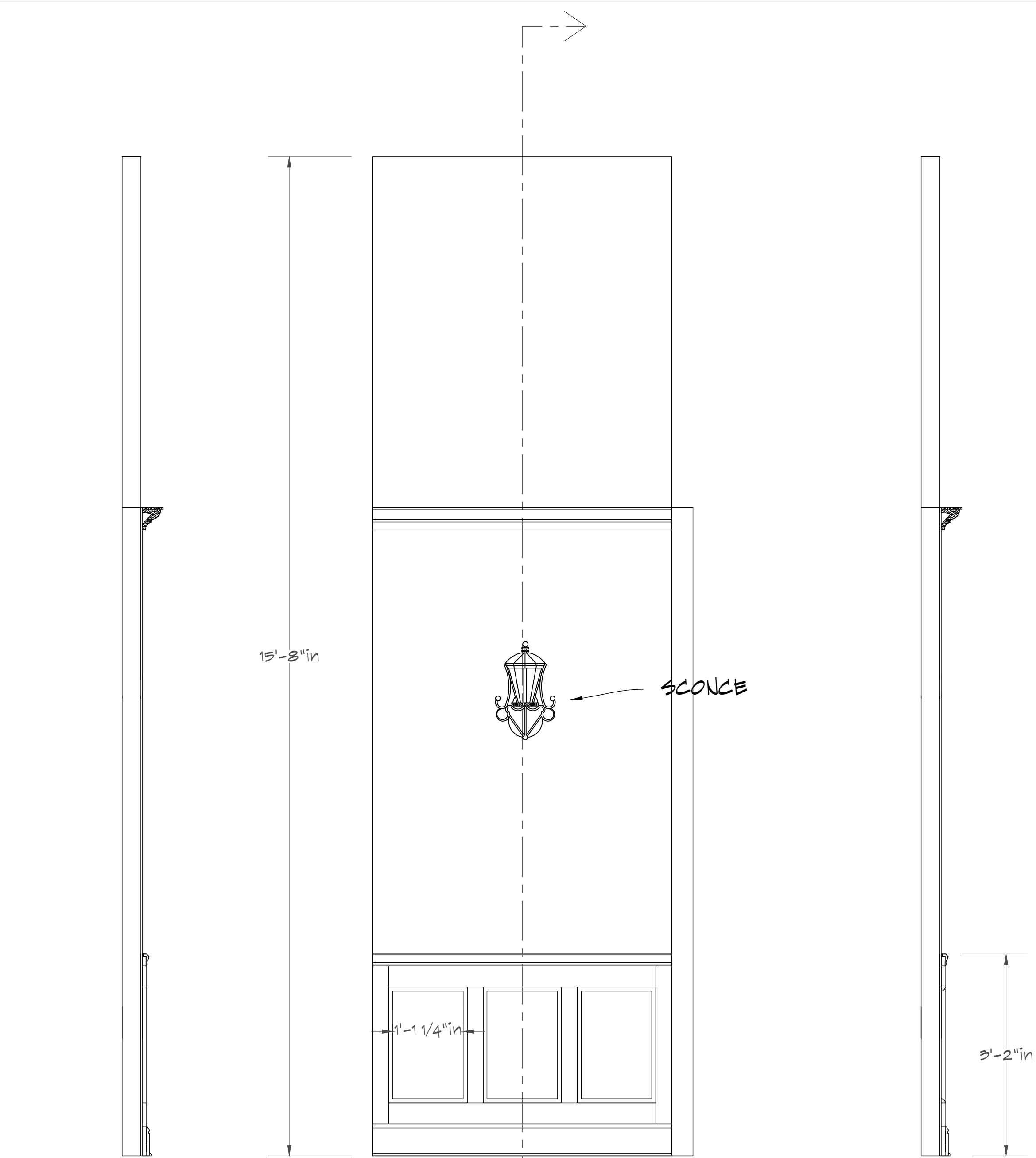

C1 SECTION VIEW

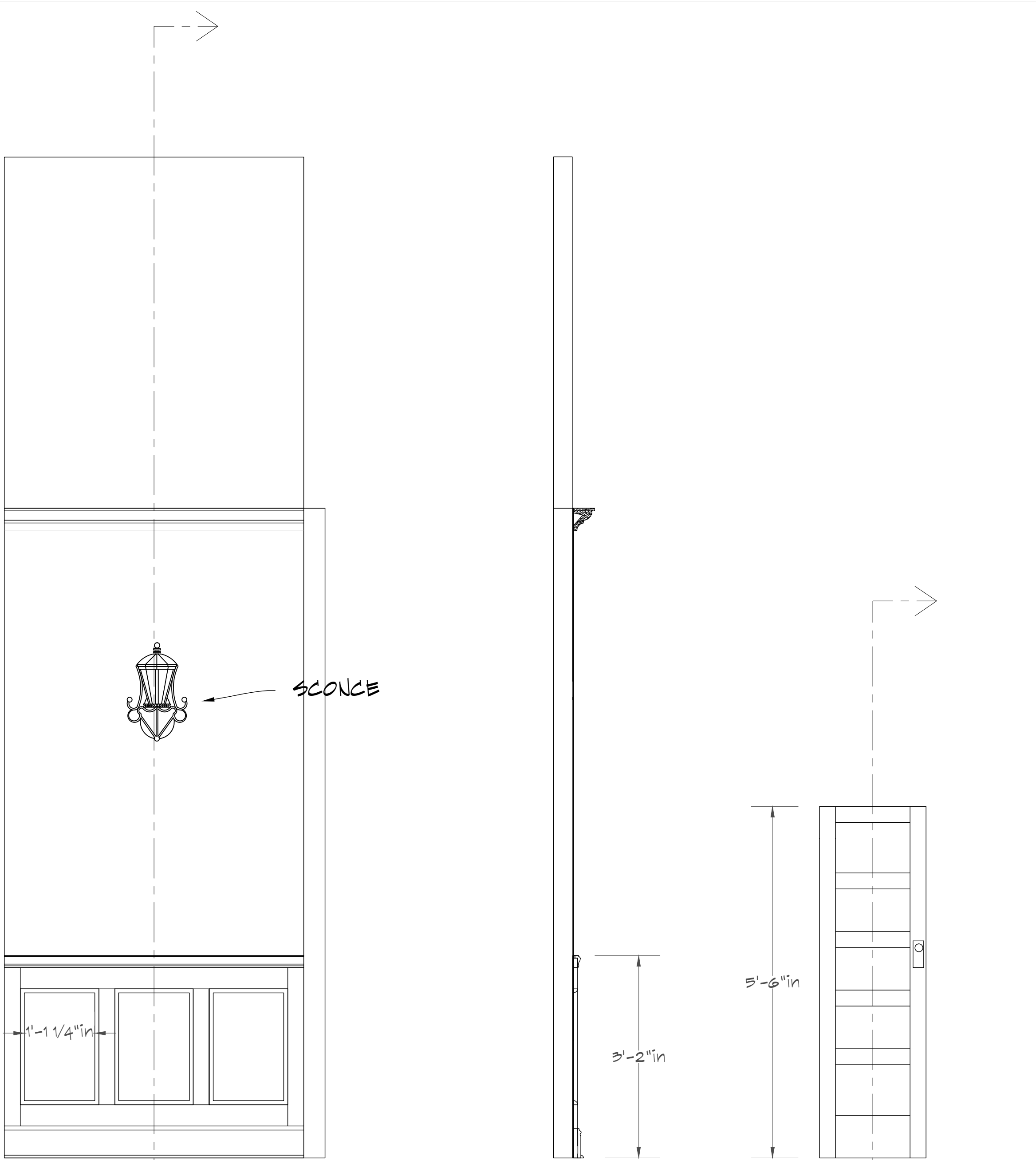

C2 ELEVATION VIEW

C2 SECTION VIEW

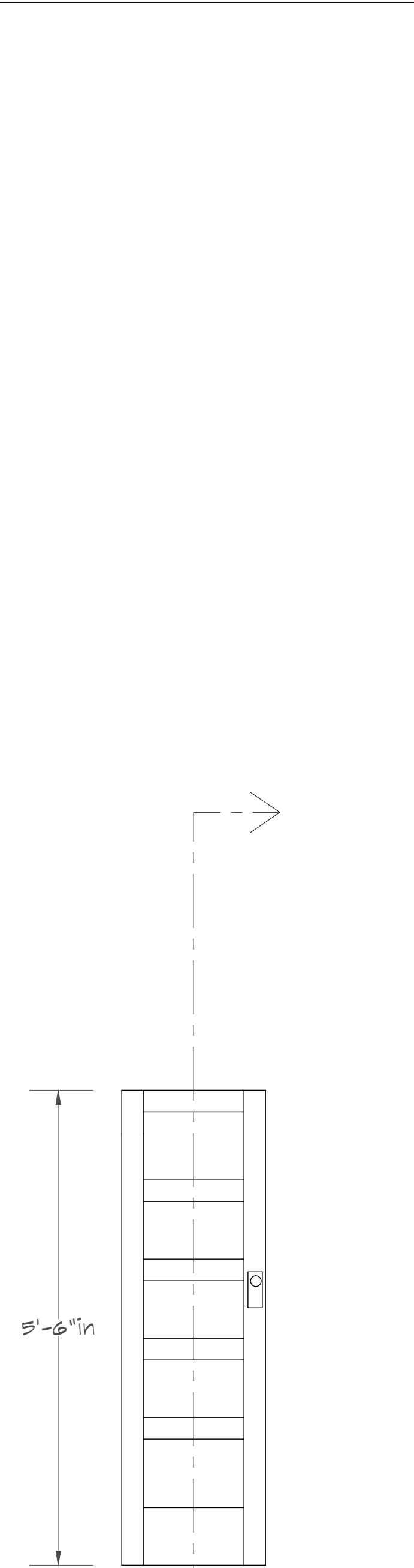

DETAIL DOOR

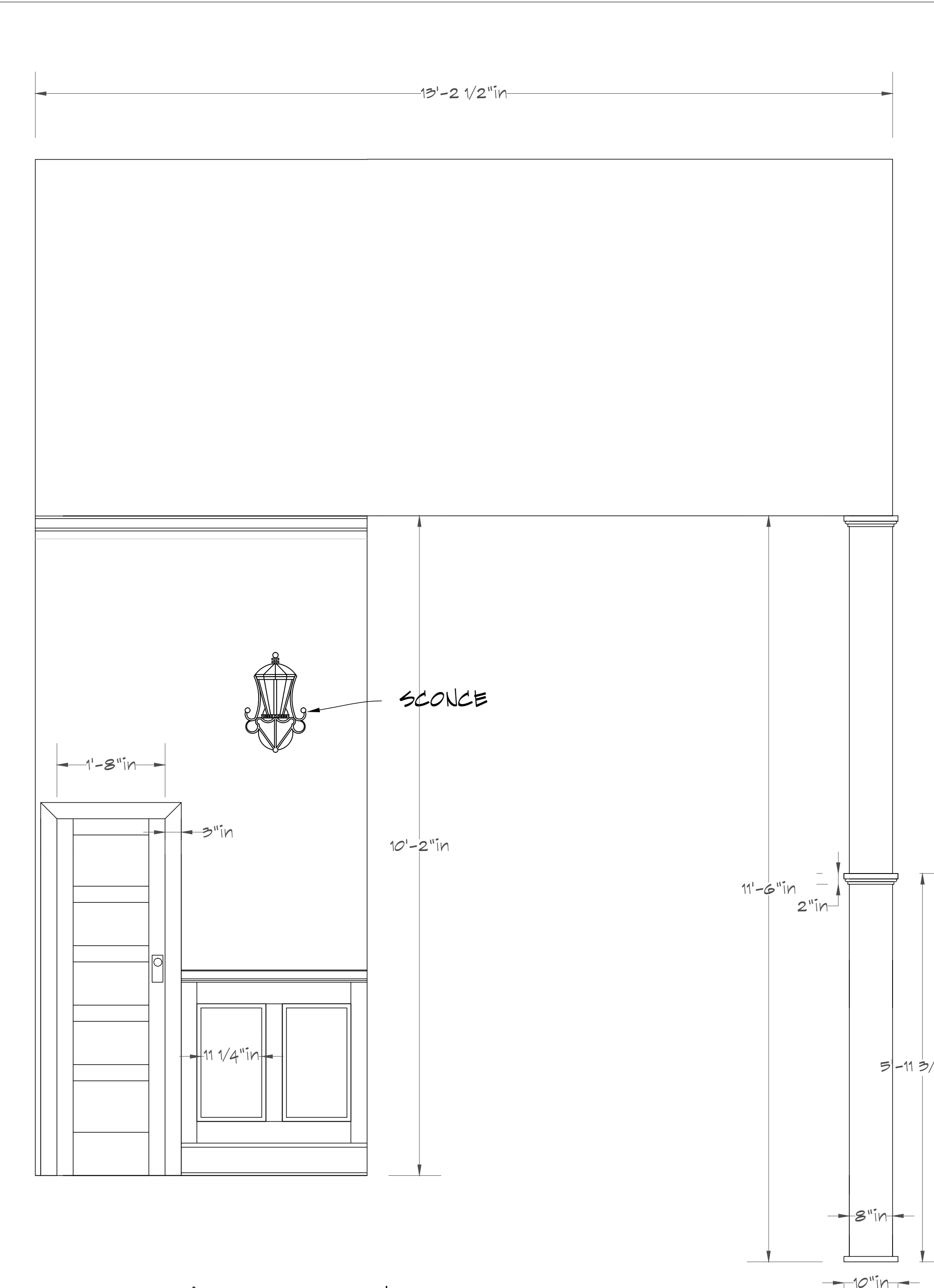

C3 ELEVATION VIEW

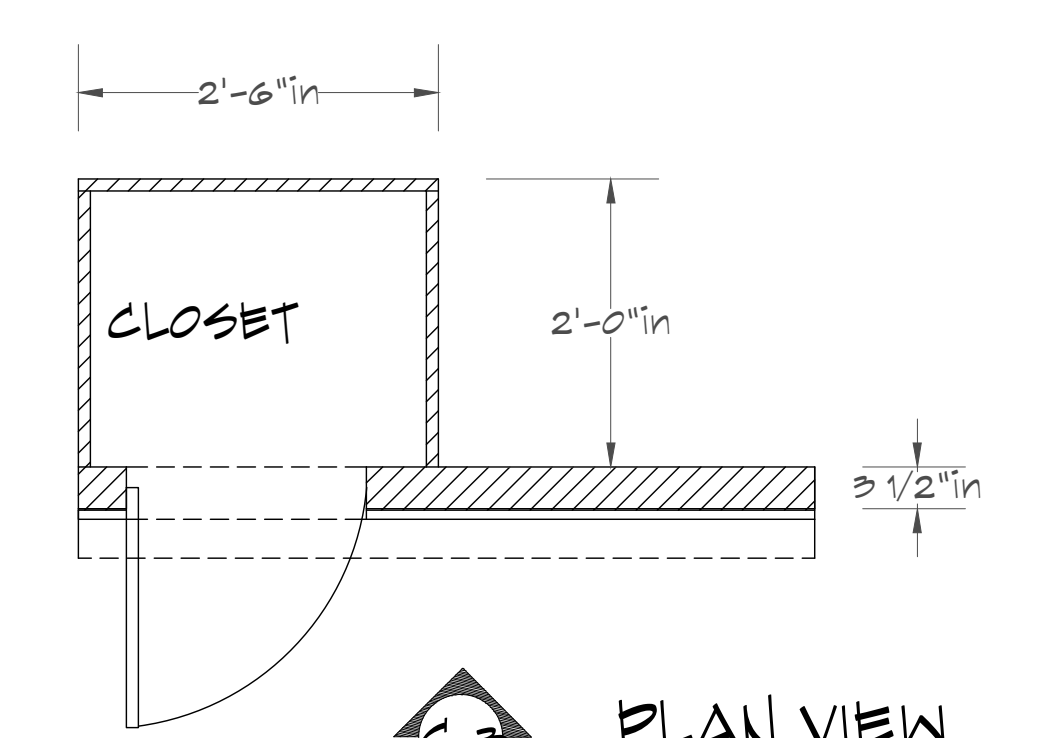

C3 PLAN VIEW

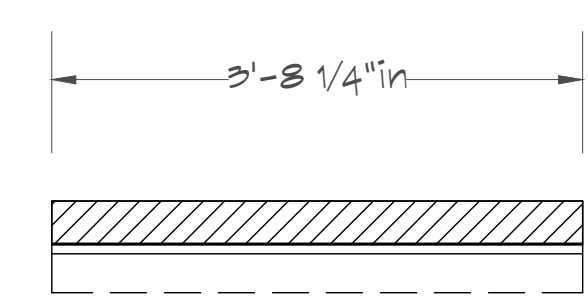

C1 PLAN VIEW

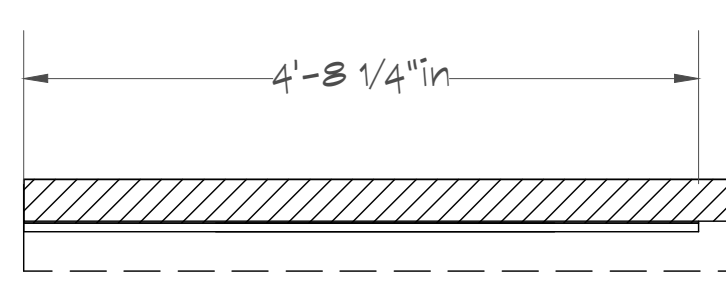

C2 PLAN VIEW

	K. April Soroko "A LONG DAY'S JOURNEY INTO NIGHT"	SHEET #
	PALM BEACH DRAMAWORKS	5
	DRAWN BY: MAURA GERGERICH	OF
	DATE: DECEMBER 7, 2013	12
	DWG: DETAIL WALLS - C 1-3	
SD 8317	SCALE: 3/4" = 1'-0"	

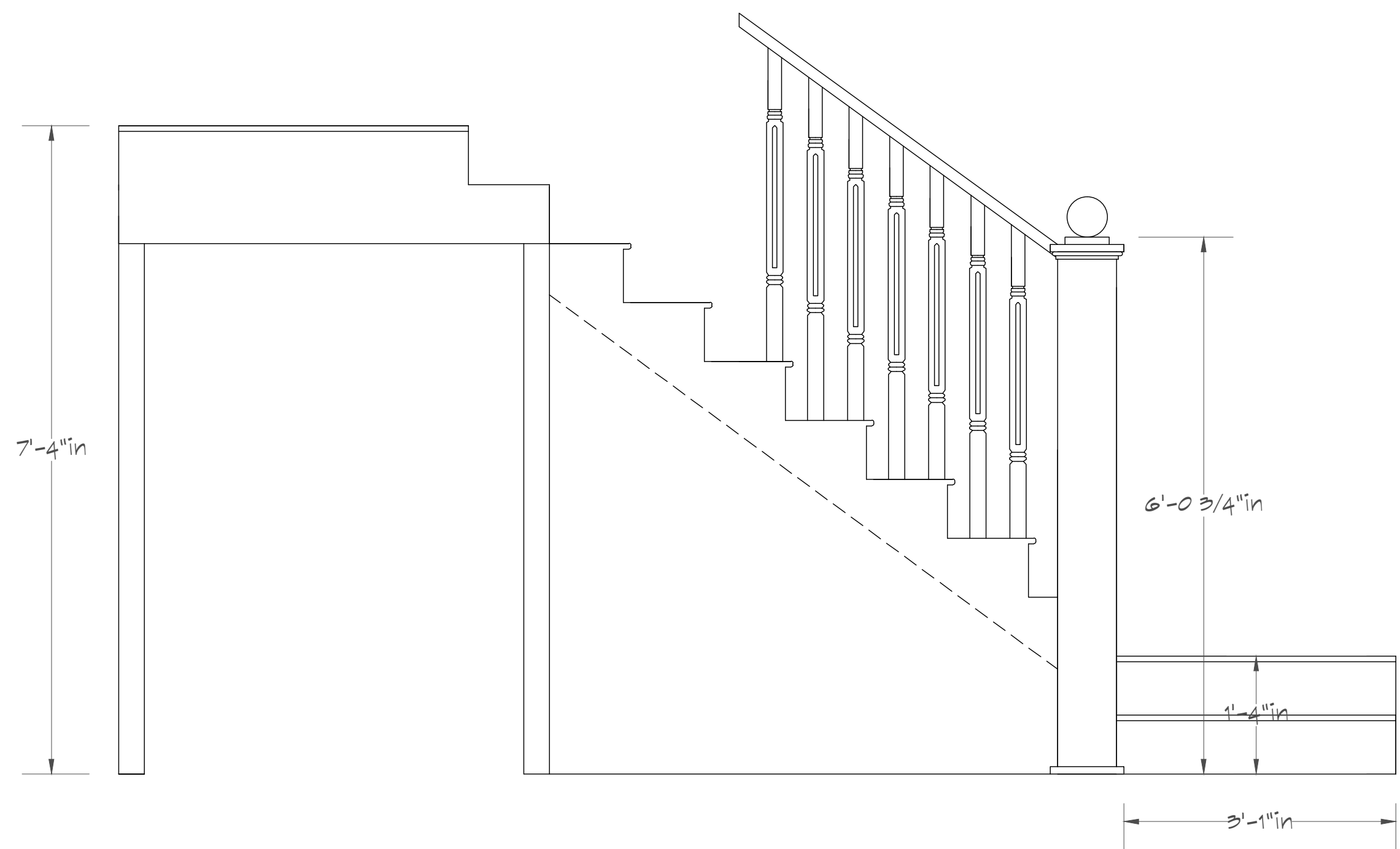

D1 ELEVATION VIEW

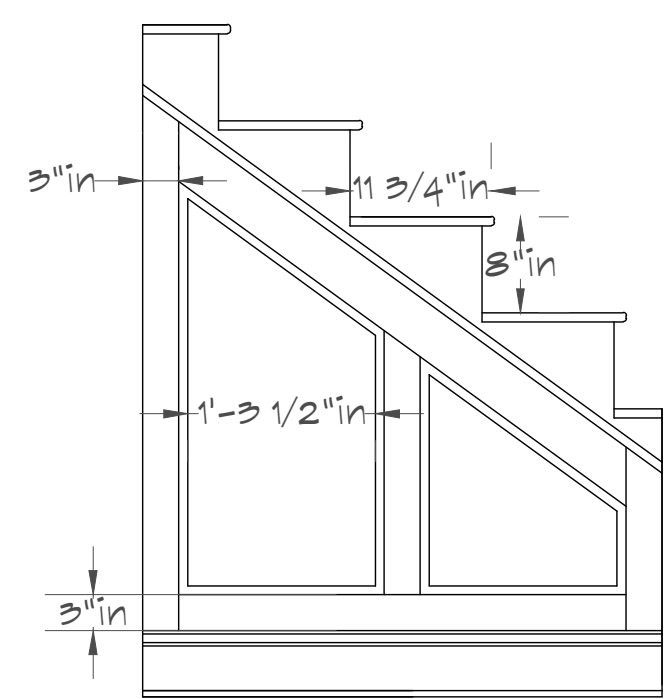

ELEVATION VIEW
DECORATIVE PANEL

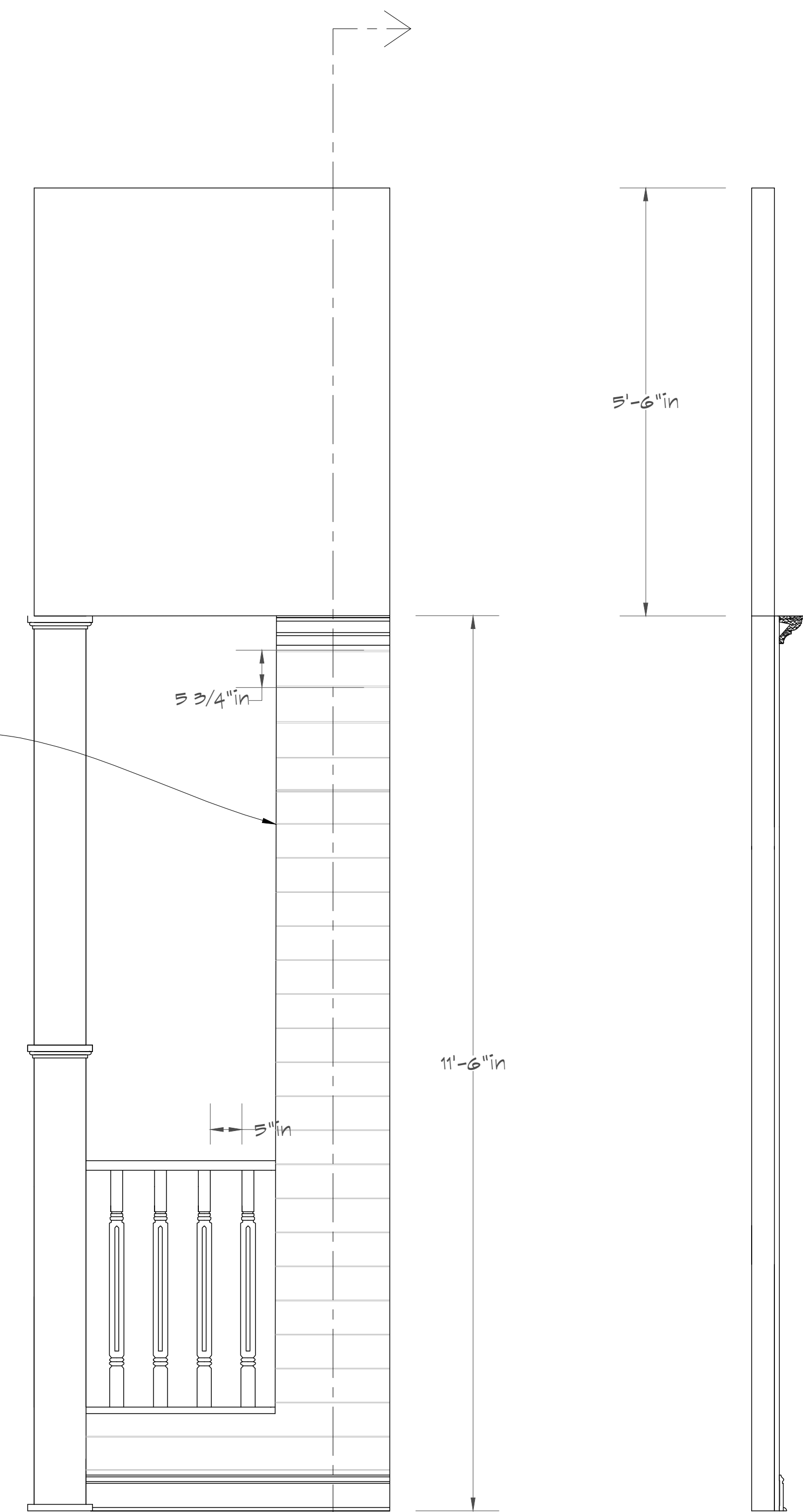

D2 ELEVATION VIEW

D2 SECTION VIEW

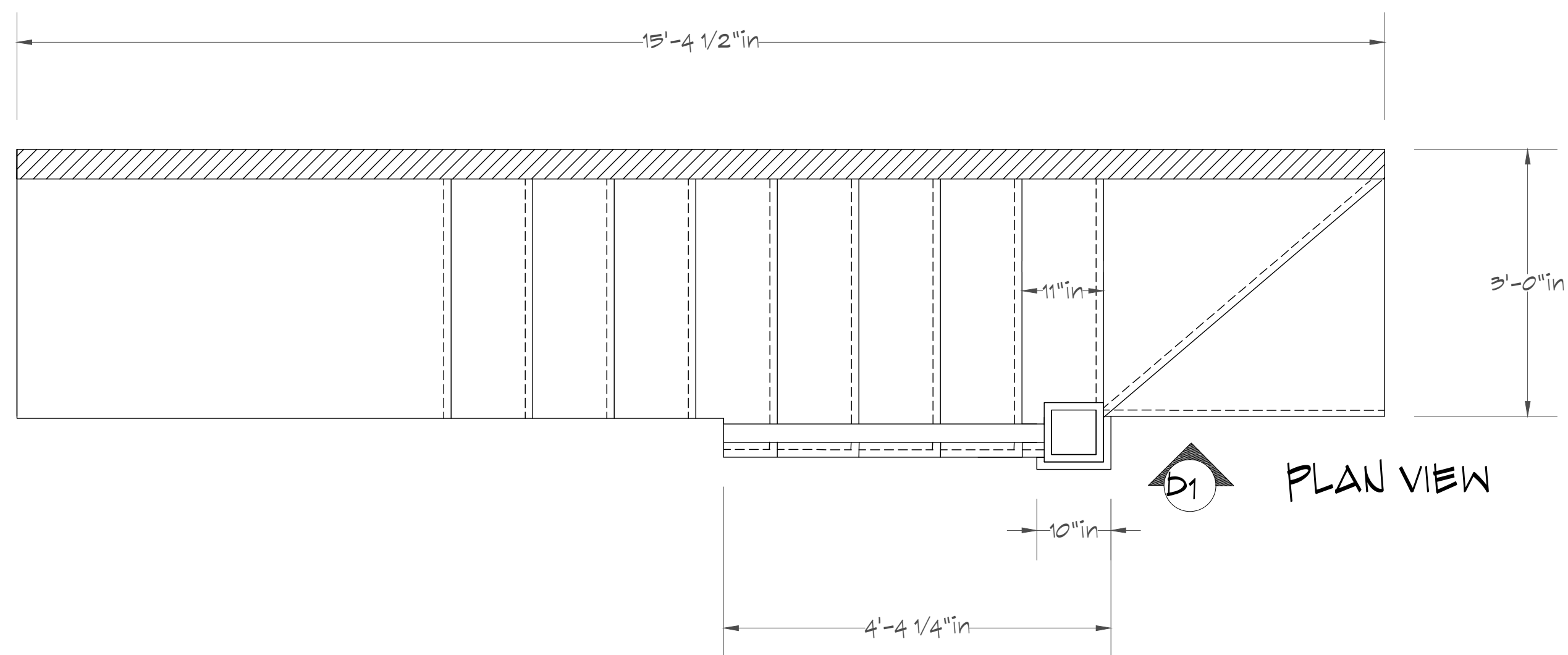

D1 PLAN VIEW

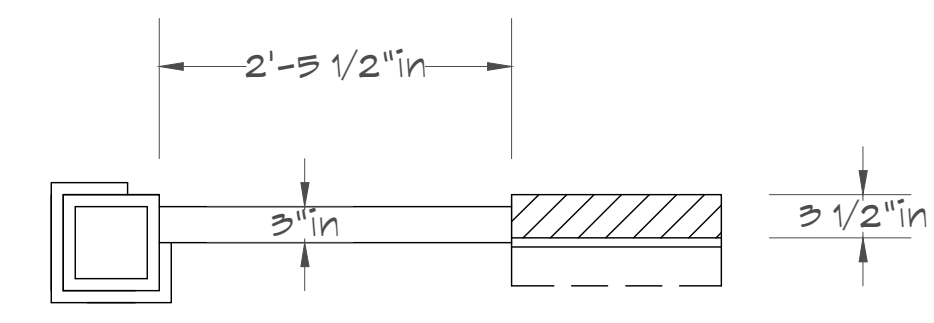

D2 PLAN VIEW

	K. April Soroko	"A LONG DAY'S JOURNEY INTO NIGHT"	SHEET #	
	PALM BEACH DRAMAWORKS			6 <small>OF</small> 12
	DRAWN BY: MAURA GERGERICH			
	DATE: DECEMBER 7, 2015			
	DWG: WALL DETAILS - D 1-2			
SCALE: 3/4" = 1'-0"				

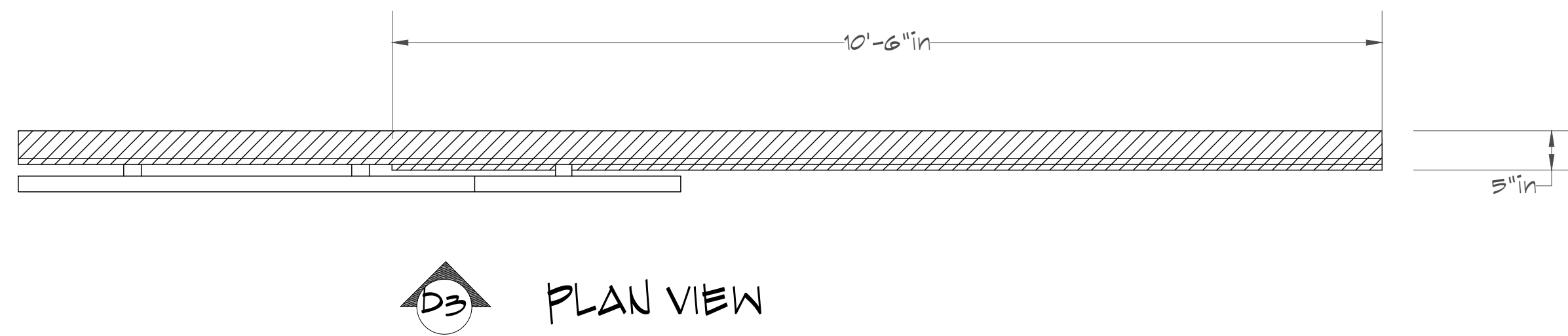
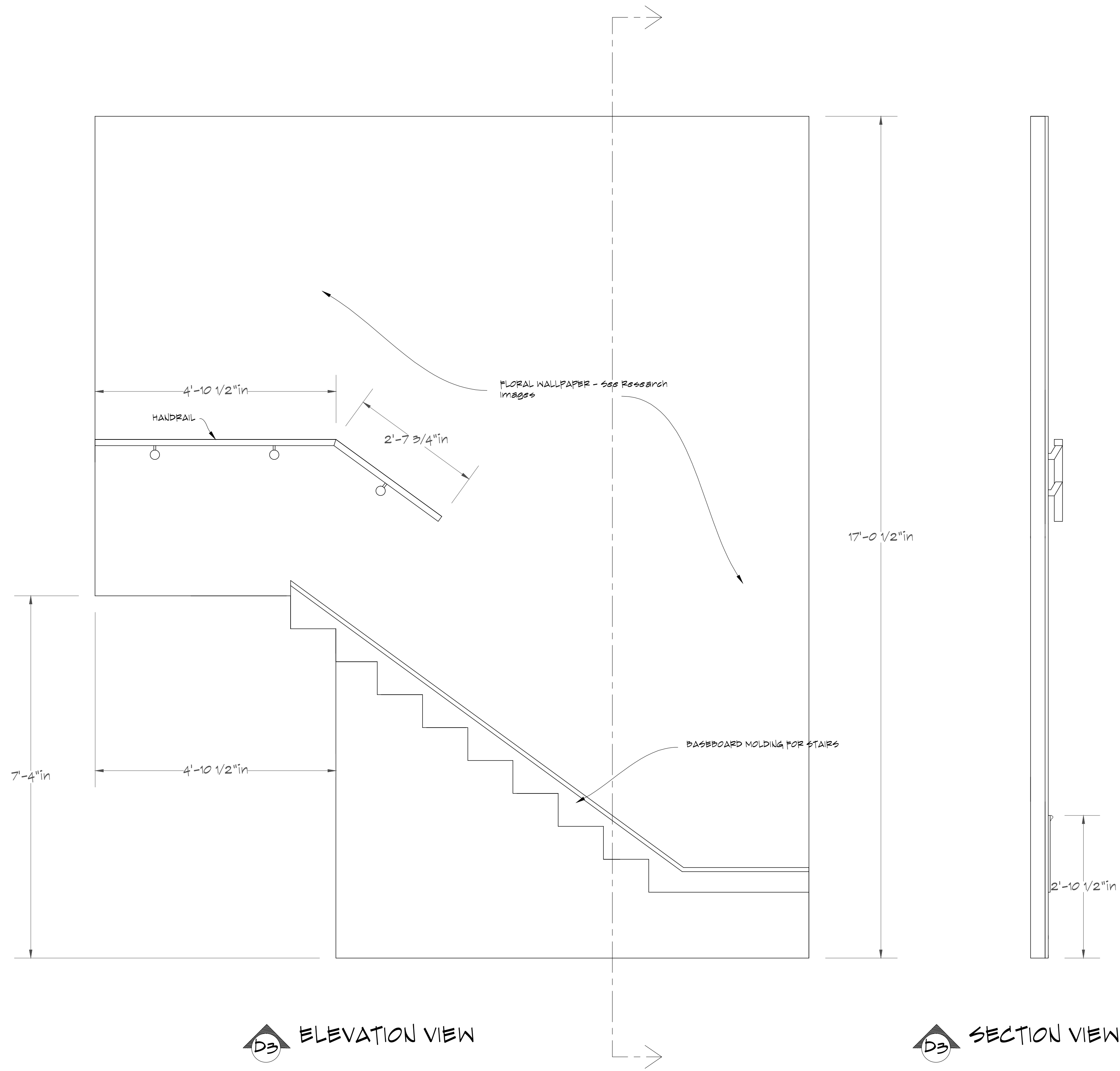

<p>SD 8317</p>	K. April Soroko "A LONG DAY'S JOURNEY INTO NIGHT" SHEET #	
	PALM BEACH DRAMAWORKS	
	DRAWN BY: MAURA GERGERICH	
	DATE: DECEMBER 7, 2015	
	Dwg: DETAIL - WALL D	
SCALE: 3/4" = 1'-0"	OR 12	

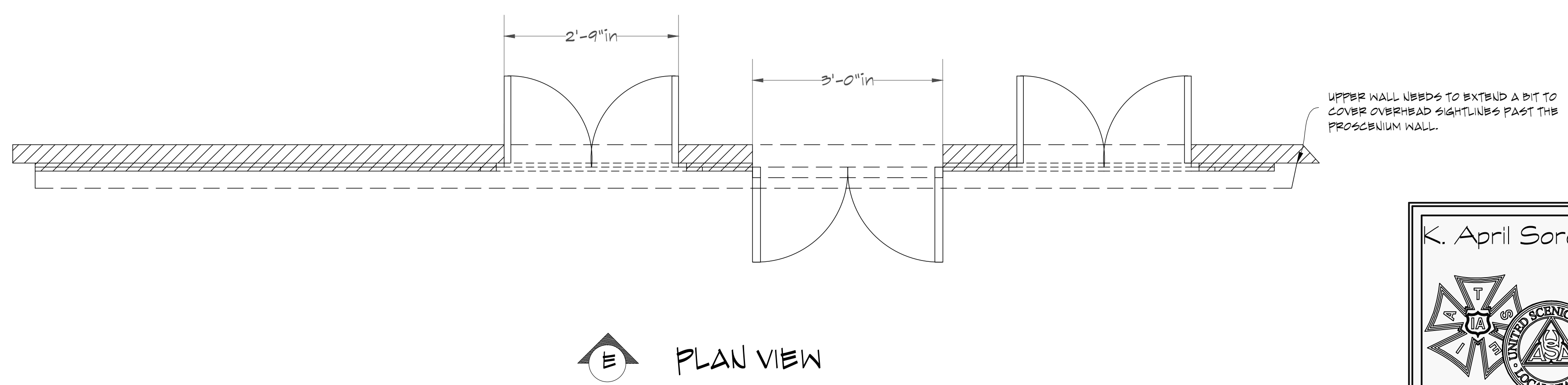
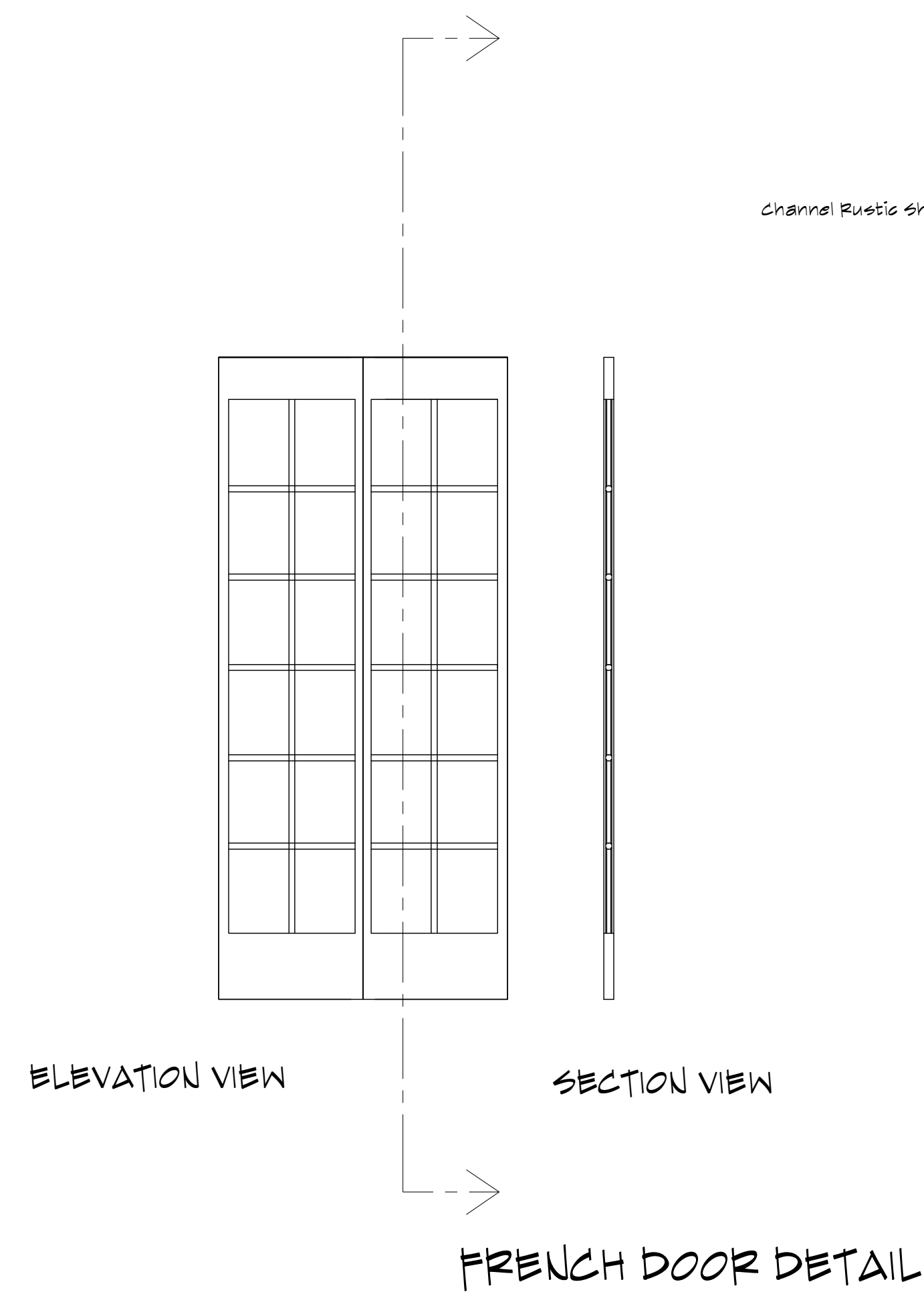

	K. April Soroko "A LONG DAY'S JOURNEY INTO NIGHT"	SHEET #
	PALM BEACH DRAMAWORKS	8
	DRAWN BY: MAURA GERGERICH	OF
	DATE: DECEMBER 7, 2015	12
	DWG: DETAIL - WALL E	
SD 8317	SCALE: 3/4" = 1'-0"	

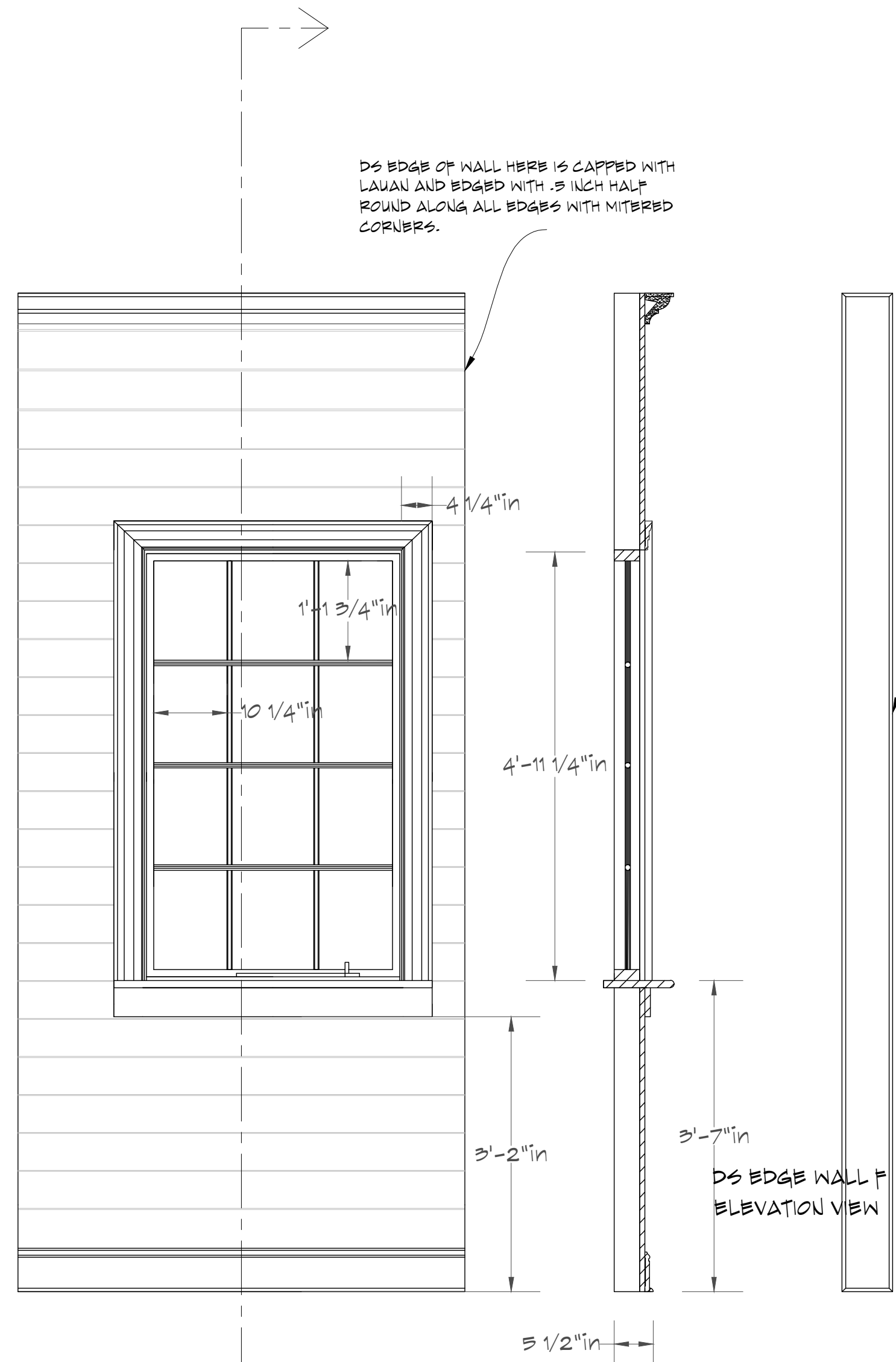

REVEAL WALL ELEVATION

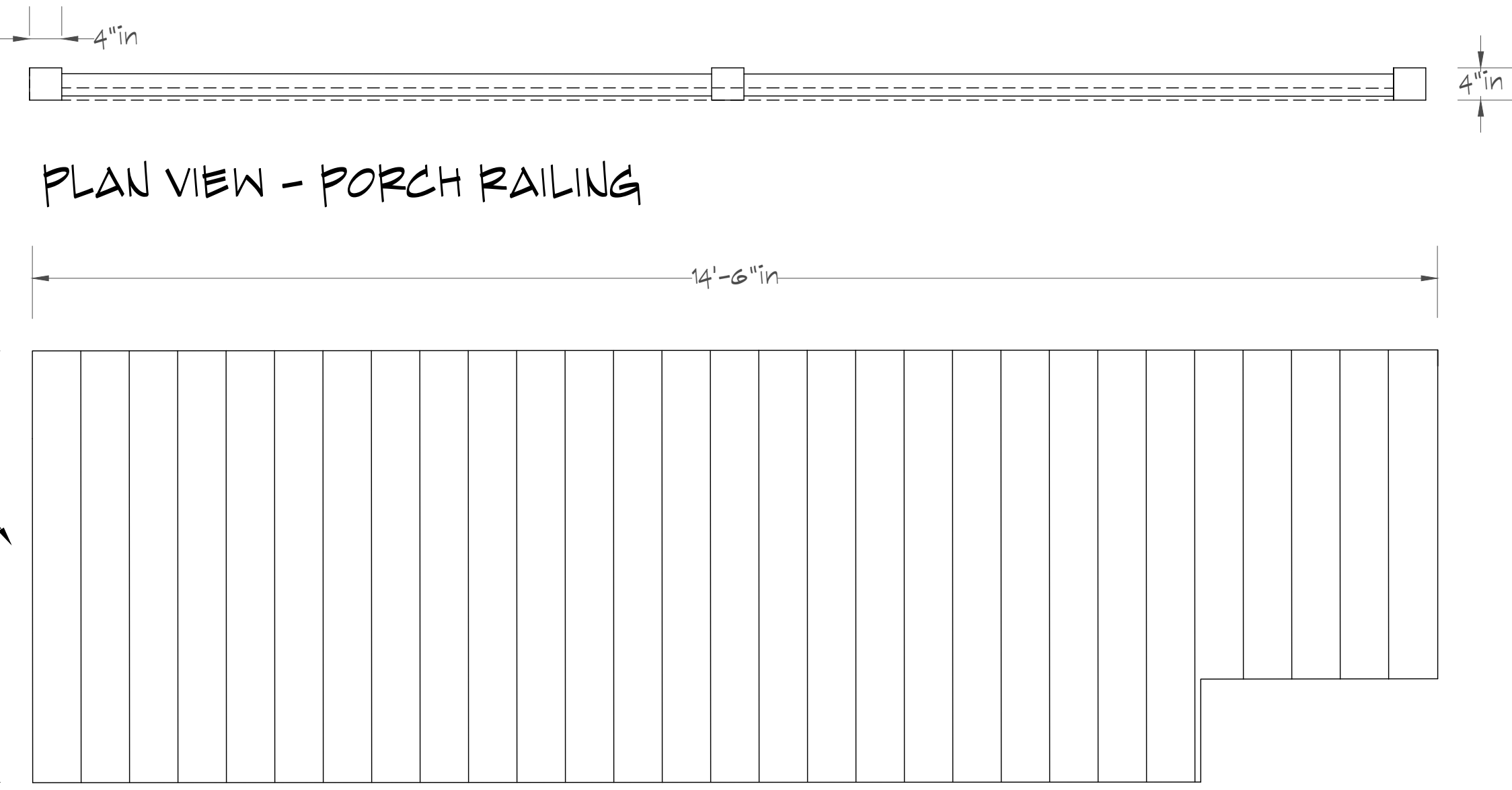
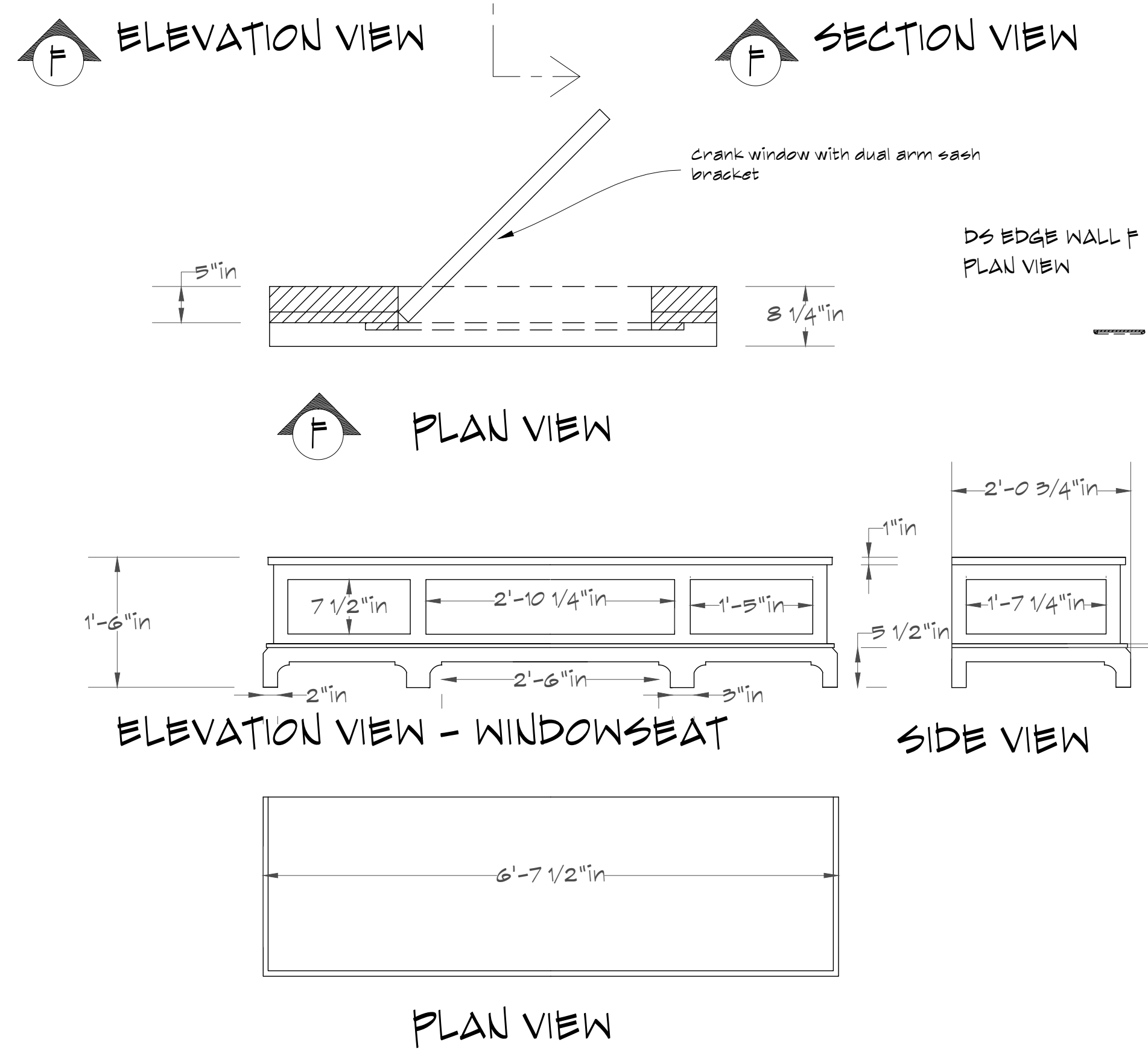
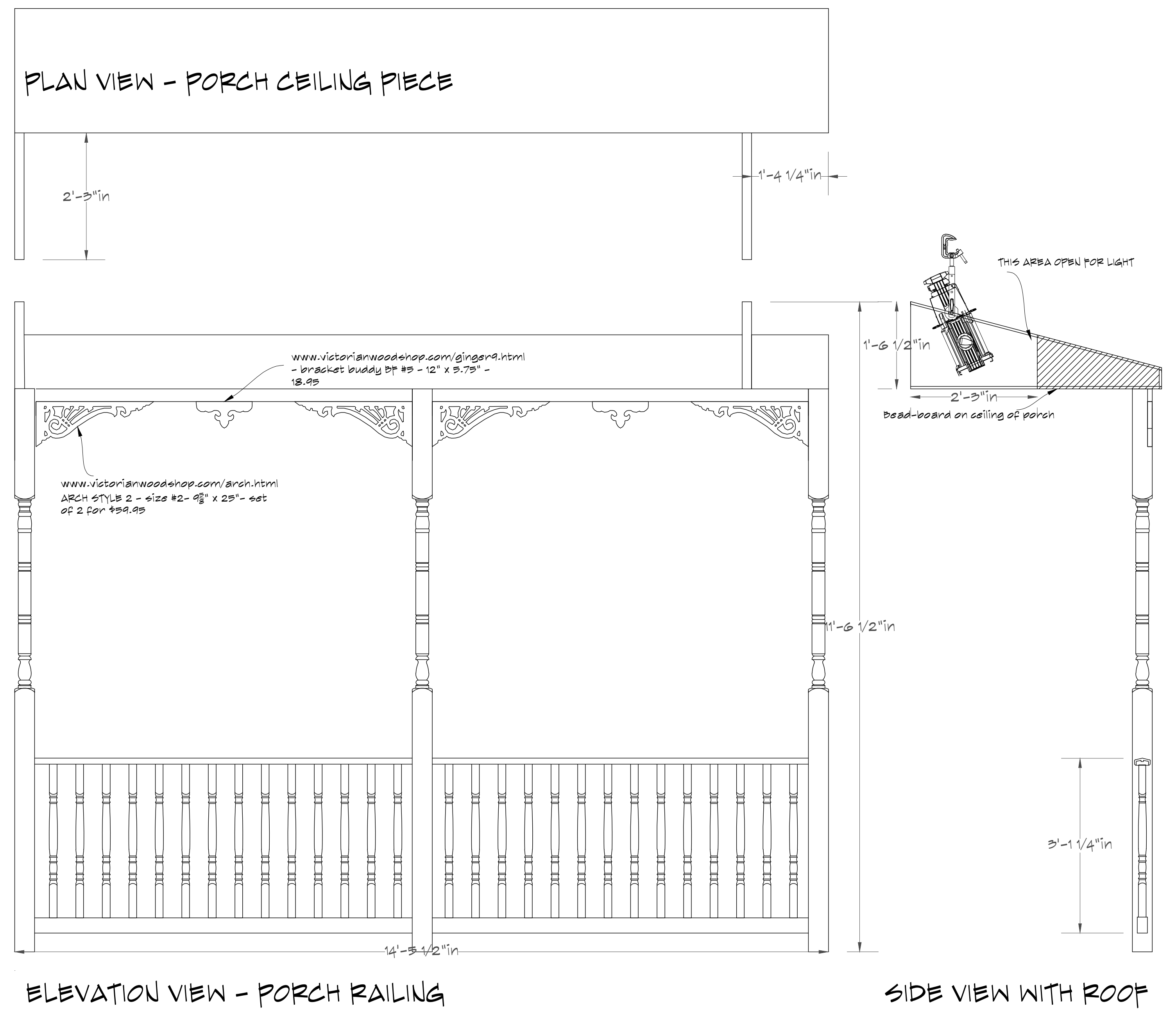
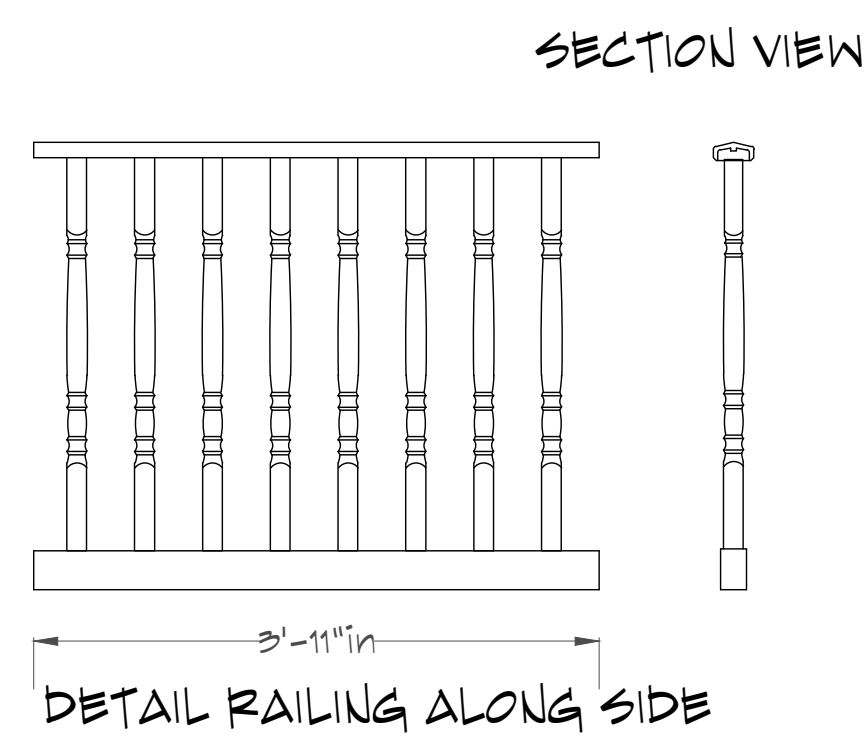

	K. April Soroko	"A LONG DAY'S JOURNEY INTO NIGHT"	SHEET #
	PALM BEACH DRAMAWORKS		9 of 12
	DRAWN BY: MAURA GERGERICH		
	DATE: DECEMBER 7, 2015		
	DWG: DETAIL- WALL F AND PORCH		
SD 8317	SCALE: 3/4" = 1'-0"		

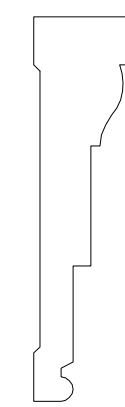

OB WILLIAMS
CASEMENT MOLDING #1187
FOR WINDOWS DS LEFT
AND DS RIGHT
1 x 4

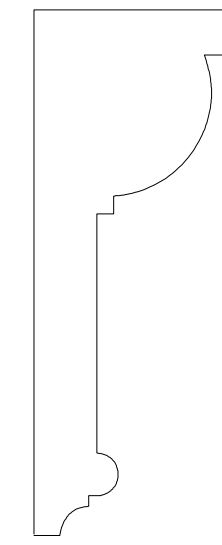

WWW.KUIKENBROTHERS.COM
KB 123 CASING
OVER MAIN DOOR



OB WILLIAMS
PANEL MOLDING
FOR WALL BEHIND
STAIRS
#3118
 $\frac{11}{16}$ x $\frac{1}{4}$



HORNER MILLWORK
CASEMENT AROUND WINDOWS ON
MAIN WALL
#N 297
1 x 3

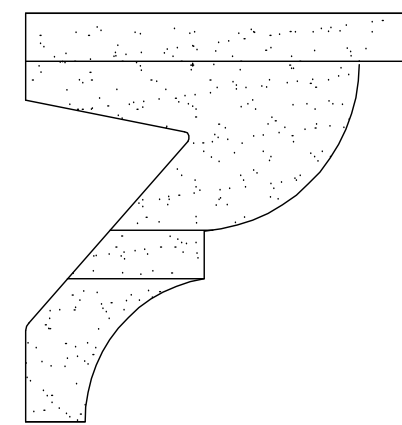

WWW.WORTHINGTONMILLWORK.COM
PRODUCT # 01-119-16
16 FEET POLYURETHANE
164.24/each
CROWN FOR ENTIRE SET

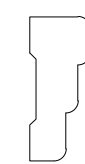

OB WILLIAMS
CASEMENT FOR LEADED WINDOWS
#3720
 $\frac{5}{8}$ x 1.5

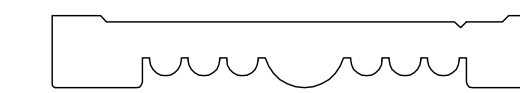

OB WILLIAMS
FLUTED PILASTER MOLDING
#1178
MAIN DOOR CASEMENT



$\frac{1}{2}$ " QUARTER ROUND FOR TOE
MOLDING OVERALL

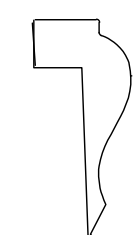

AZEK BUILDING PRODUCTS
WAINSCOTING CAP
PRODUCT # AZM-284
WWW.AZEK.COM

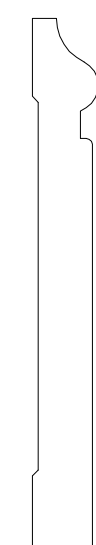

OB WILLIAMS
BASE MOLDING #3813
BASEBOARD FOR ENTIRE SET
 $\frac{3}{4}$ x 5.5

	K. April Soroko	"A LONG DAY'S JOURNEY INTO NIGHT"	SHEET #
	PALM BEACH DRAMAWORKS		10
	DRAWN BY: MAURA GERGERICH		
	DATE: DECEMBER 7, 2015		OF 12
	DWG: MOLDINGS DETAILS		
SD 8317	SCALE: 6" = 1'-0"		

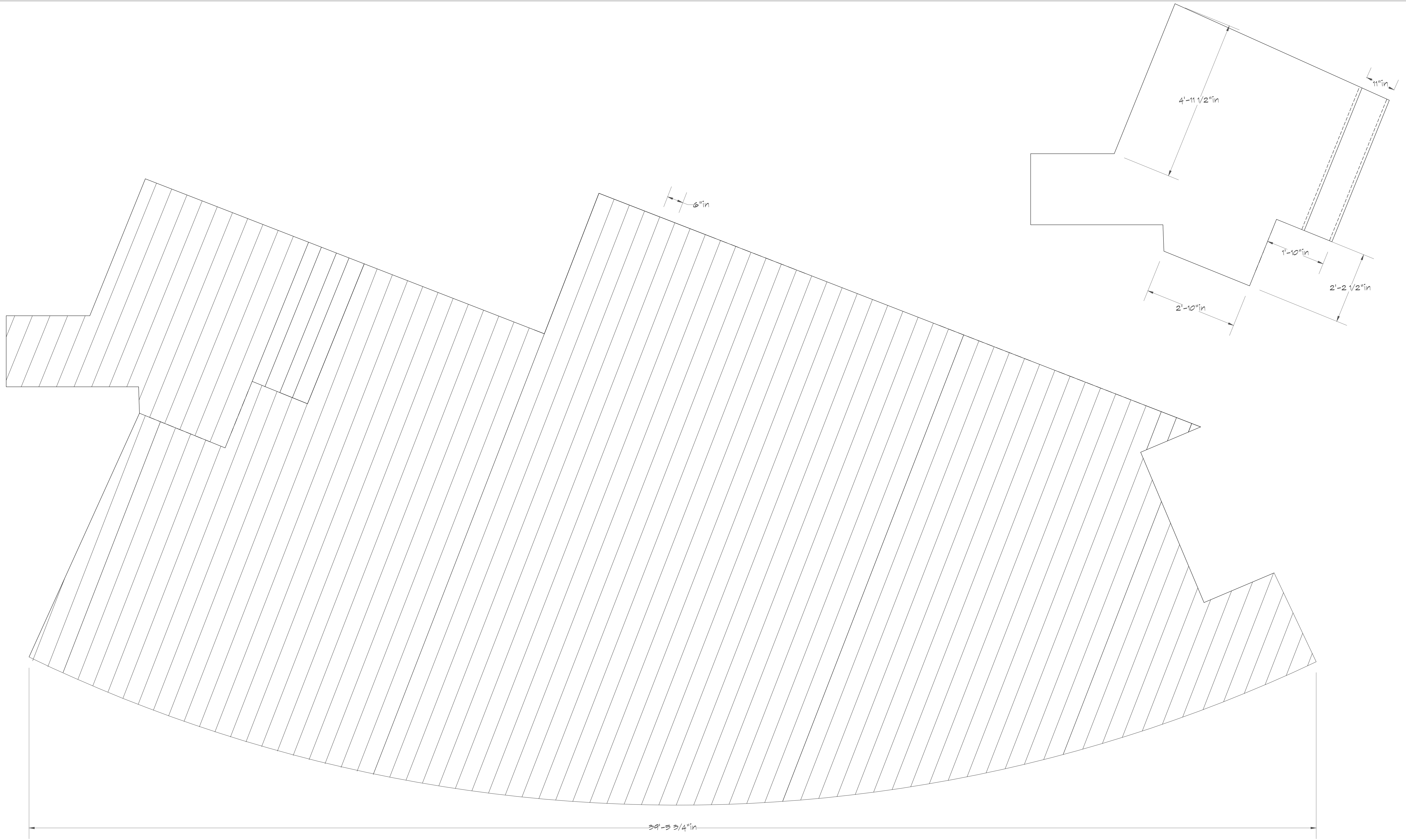

	K. April Soroko "A LONG DAY'S JOURNEY INTO NIGHT"	SHEET #
	PALM BEACH DRAMAWORKS	11
	DRAWN BY: MAURA GERGERICH	OF
	DATE: DECEMBER 7, 2015	12
	DWG: PLAN VIEW FLOOR LAYOUT	
SD 8317	SCALE: 3/4" = 1'-0"	

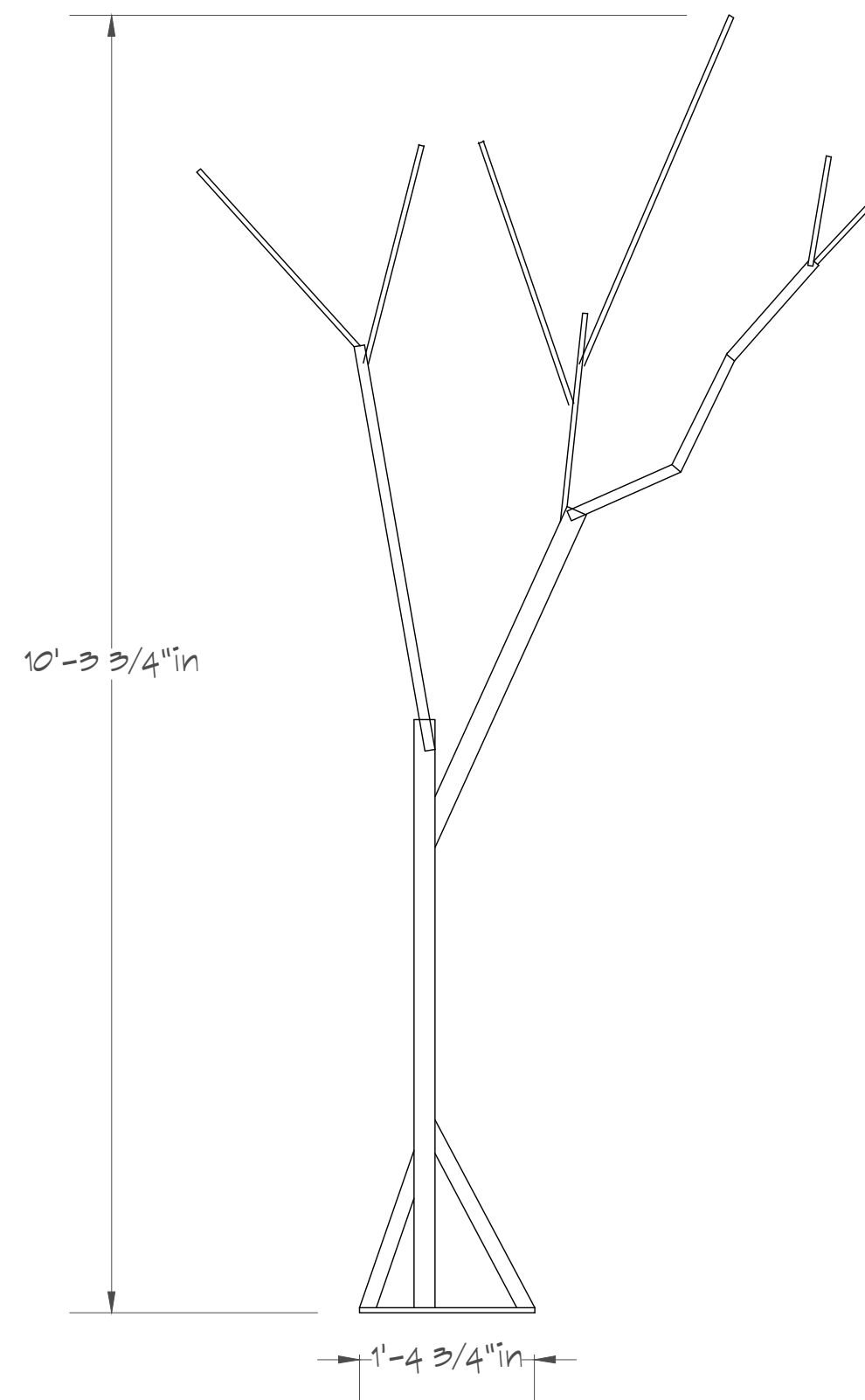

ELEVATION VIEW

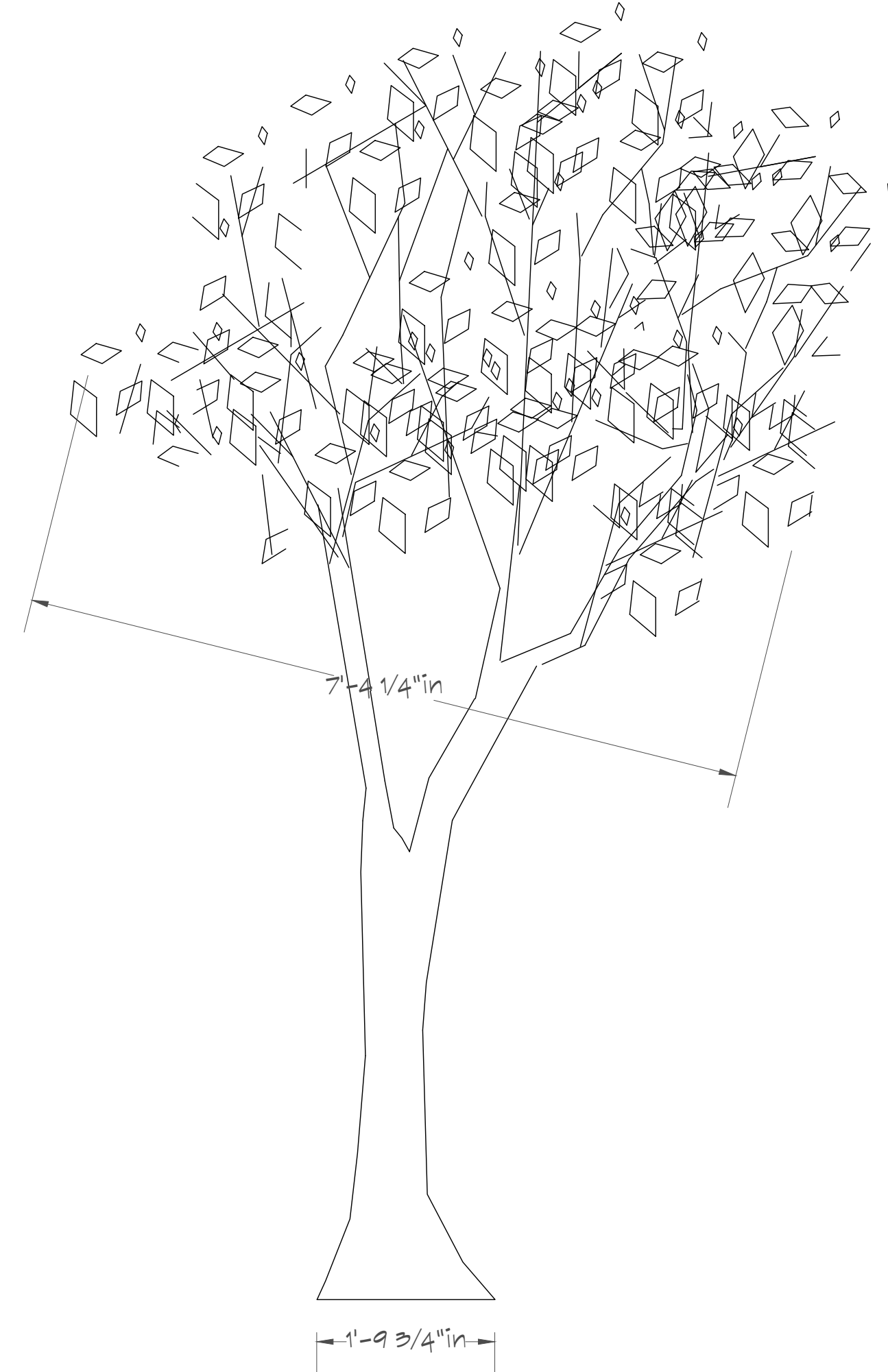

WITH SONOTUBE AND CRAFT PAPER
REVERSE AND REPEAT FOR SL SIDE

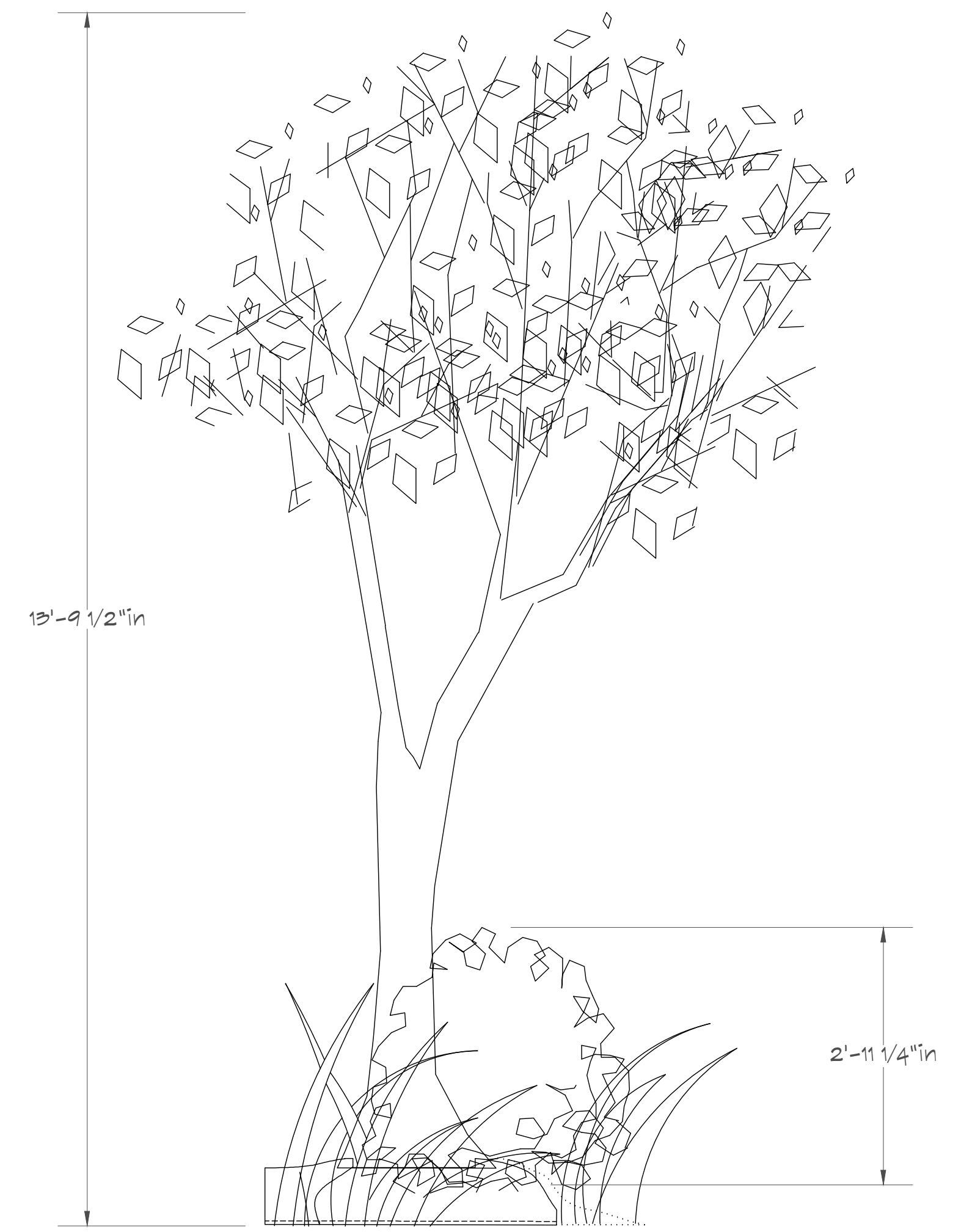

DOWNSTAGE OF THE LARGE TREE, ON EACH SIDE, THERE IS ROOM FOR SMALL FAUX BOXWOOD SHRUBS (ONE ON EACH SIDE) AND LONGER FAKE GRASS. THESE ELEMENTS CAN BE SECURED TO THE FOAM BASE BY CREATING HOLES IN THE FOAM AND ATTACHING THE STEM OF THE SHRUB TO THE BASE.

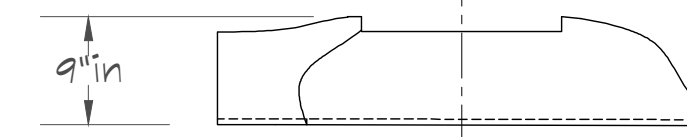

ELEVATION

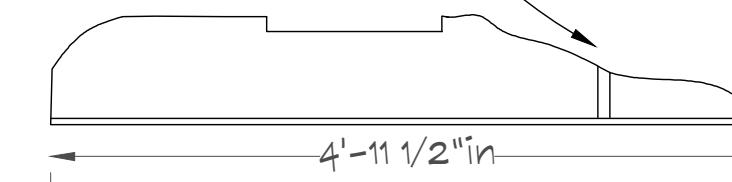

SECTION

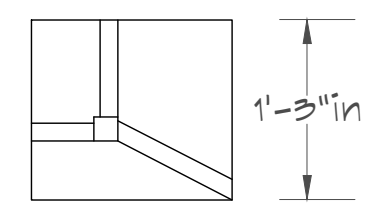

PLAN VIEW - LARGE TREE

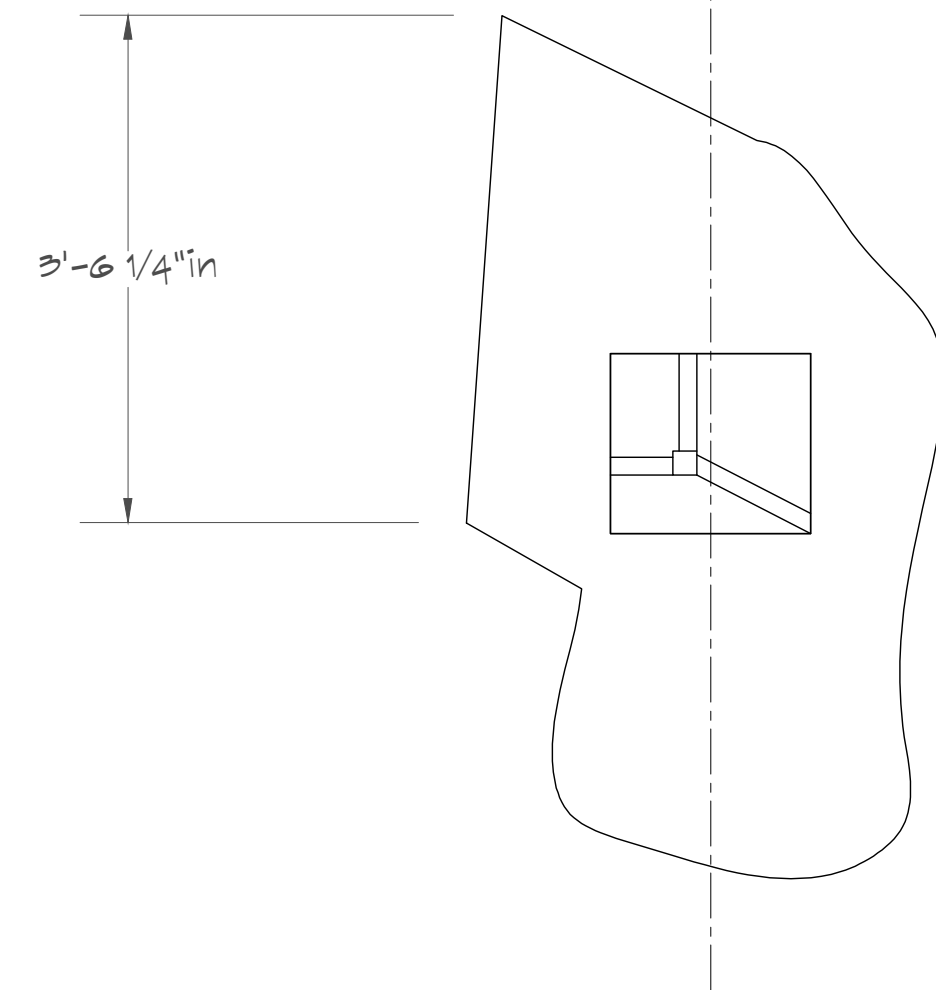

PLAN VIEW - LARGE TREE BASE
PLYWOOD COVERED WITH BLUE FOAM
CARVED AND COVERED WITH "GRASS"

THIS CARVED FOAM BASE CAN BE COVERED WITH JADE SO ARTIFICIAL GRASS AVAILABLE FROM HOME DEPOT AT \$18/LINEAR FOOT. THE GRASS SHOULD EXTEND OUT ALONG THE OFFSTAGE EDGE BY AT LEAST 1'-0".

	K. April Soroko "A LONG DAY'S JOURNEY INTO NIGHT" SHEET #	
	PALM BEACH DRAMAWORKS	12 OF 12
	DRAWN BY: MAURA GERGERICH	
	DATE: DECEMBER 7, 2015	
	DWG: LARGE TREE DETAILS	
SD 8317	SCALE: 3/4" = 1'-0"	